

Tapered Roller Bearings

Metric Series

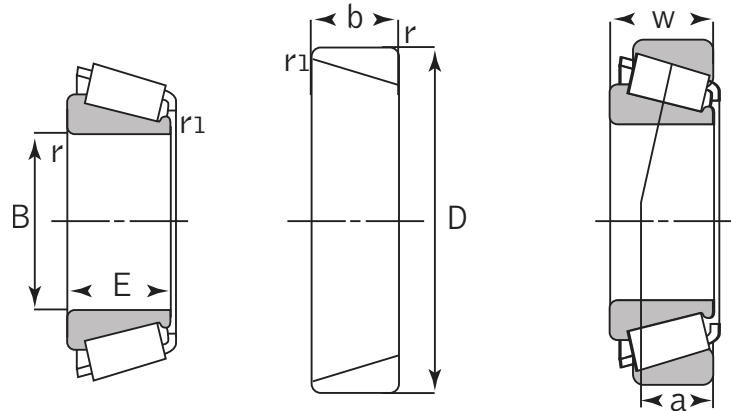

32000

Ass'y No.	Cone Bore	Cup O.D.	Bearing W.	Cone W.	Cup W.	Max. Shaft fillet Rad.	Max. Hang. Fillet Rad.	Weight (lbs)
	(mm)	(mm)	(mm)	(mm)	(mm)	(mm)	(mm)	
	B	D	W	E	b	R	r1	
32006	30	55	17	17	13	1	1	0.37
32007	35	62	18	18	14	1	1	0.51
32008	40	68	19	19	14.5	1	1	0.59
32009	45	75	20	20	15.5	1	1	0.77
32010	50	80	20	20	15.5	1	1	0.81
32011	55	90	23	23	17.5	1.5	1.5	1.25
32012	60	95	23	23	17.5	1.5	1.5	1.32
32013	65	100	23	23	17.5	1.5	1.5	1.41
32014	70	110	25	25	19	1.5	1.5	1.91
32015	75	115	25	25	19	1.5	1.5	2.02
32016	80	125	29	29	22	1.5	1.5	2.82
32017	85	130	29	29	22	1.5	1.5	2.97
32018	90	140	32	32	24	2	1.5	3.81
32019	95	145	32	32	24	2	1.5	3.96
32020	100	150	32	32	24	2	1.5	4.18
32021	105	160	35	35	26	2.5	2	5.28
32022	110	170	38	38	29	2.5	2	6.80
32024	120	180	38	38	29	2.5	2	7.30
32026	130	200	45	45	34	2.5	2	11.13
32028	140	210	45	45	34	2.5	2	11.68
32030	150	225	48	48	36	3	2.5	13.82
32040	200	310	70	70	53	3	2.5	42.90
32044	220	340	76	76	57	4	3	56.10
32048	240	360	76	76	76	4	3	56.54
32064	320	480	100	100	74	5	4	138.60