

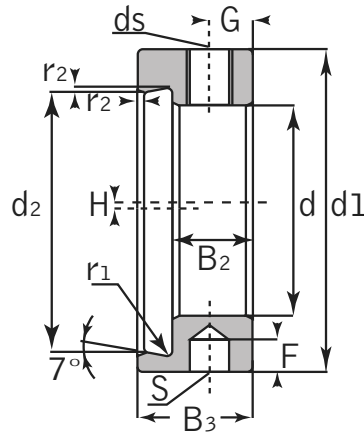

Locking Collar

Eccentric Collar Series



A 200

Unit No.	Shaft Dia. (inch / mm)	Dimensions (inch / mm)											Mass	
	d	d ₁	d ₂	B ₂	B ₃	H	r ₁	r ₂	G	F	S	d _s	kg	lbs
A 201	12 mm													
201-8	1/2													
202	15 mm	1.1260	0.8503	0.374	0.5315	0.0315	0.0157	0.0315	0.1969	0.1378	0.1969	1/4-28 UNF	0.05	0.11
202-10	5/8	28.6	21.6	9.5	13.5	0.8	0.4	0.8	5	3.5	5	M6 x 1	0.05	0.11
203	17 mm													
203-11	11/16													
A 204	20 mm	1.3110	1.0472	0.374	0.5315	0.0315	0.0157	0.0315	0.1969	0.1575	0.1969	1/4-28 UNF	0.06	0.14
204-12	3/4	33.3	26.6	9.5	13.5	0.8	0.4	0.8	5	4	5	M6 x 1		
A 205	25 mm												0.06	0.13
205-14	7/8	1.500	1.2441	0.374	0.5315	0.0315	0.0157	0.0315	0.1969	0.1575	0.1969	1/4-28 UNF	0.07	0.15
205-15	15/16	38.1	31.6	9.5	13.5	0.8	0.4	0.8	5	4	5	M6 x 1	0.06	0.13
205-16	1												0.06	0.13
A 206	30 mm												0.10	0.22
206-18	1-1/8	1.7520	1.4921	0.4685	0.6260	0.0315	0.0157	0.0315	0.2362	0.1575	0.1969	1/4-28 UNF	0.10	0.22
206-19	1-3/16	44.5	37.9	11.9	15.9	0.8	0.4	0.8	6	4	5	M6 x 1	0.10	0.22
206-20	1-1/4												0.09	0.20
A 207	35 mm												0.18	0.40
207-20	1-1/4												0.20	0.44
207-21	1-5/16	2.1890	1.7598	0.5315	0.6890	0.0315	0.0157	0.0315	0.2559	0.1969	0.2756	5/16-24 UNF	0.19	0.42
207-22	1-3/8	55.6	44.7	13.5	17.5	0.8	0.4	0.8	6.5	5	7	M8 x 1	0.18	0.40
207-23	1-7/16												0.17	0.37
A 208	40 mm												0.21	0.46
208-24	1-1/2	2.3740	1.9449	0.5315	0.7205	0.0630	0.0157	0.0472	0.2559	0.1969	0.2756	5/16-24 UNF	0.20	0.44
208-25	1-9/16	60.3	49.4	13.5	18.3	1.6	0.4	1.2	6.5	5	7	M8 x 1	0.21	0.46

Locking Collar

Eccentric Collar Series

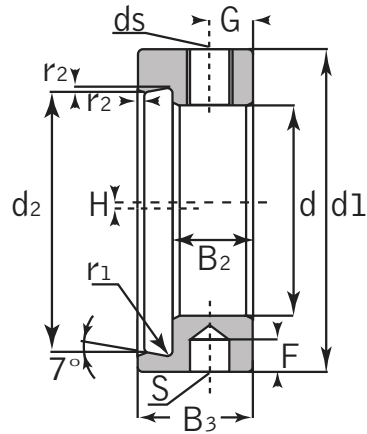

A 200

Unit No.	Shaft Dia. (inch / mm)	Dimensions (inch / mm)											Mass	
	d	d1	d2	B2	B3	H	r1	r2	G	F	S	ds	kg	lbs
A 209	45 mm													
209-26	1-5/8	2.500	2.1417	0.5315	0.7205	0.0630	0.0157	0.0472	0.2559	0.1969	0.2756	5/16-24 UNF	0.22	0.48
209-27	1-11/16	63.5	54.4	13.5	18.3	1.6	0.4	1.2	6.5	5	7	M8 x 1	0.25	0.55
209-28	1-3/4												0.22	0.48
A 210	50 mm													
210-30	1-7/8	2.7520	2.3228	0.5315	0.7205	0.0630	0.0157	0.0472	0.2559	0.1969	0.2756	5/16-24 UNF	0.24	0.53
210-31	1-15/16	69.9	59	13.5	18.3	1.6	0.4	1.2	6.5	5	7	M8 x 1	0.26	0.57
210-32	2												0.25	0.55
A 211	55 mm													
211-32	2	3.000	2.5906	0.6260	0.8150	0.0630	0.0236	0.0472	0.3150	0.2362	0.3307	3/8-24 UNF	0.32	0.70
211-34	2-1/8	76.2	65.8	15.9	20.7	1.6	0.6	1.2	8	6	8.4	M10 x 1.25	0.36	0.79
211-35	2-3/16												0.33	0.73
													0.27	0.59
A 212	60 mm													
212-36	2-1/4	3.3150	2.8228	0.6260	0.8780	0.0630	0.0236	0.0630	0.3150	0.2362	0.3307	3/8-24 UNF	0.41	0.90
212-38	2-3/8	84.2	71.7	15.9	22.3	1.6	0.6	1.6	8	6	8.4	M10 x 1.25	0.44	0.97
212-39	2-7/16												0.41	0.90
													0.38	0.84
A 213	65 mm													
213-40	2-1/2	3.3858	3.1102	0.6890	0.9252	0.0630	0.0236	0.0630	0.3346	0.2362	0.3307	3/8-24 UNF	0.39	0.86
		86	79	17.5	23.5	1.6	0.6	1.6	8.5	6	8.4	M10 x 1.25	0.41	0.90
A 214	70 mm													
214-43	2-11/16	3.8110	3.2795	0.6732	0.9252	0.0630	0.0236	0.0630	0.3346	0.2362	0.3465	3/8-24 UNF	0.40	0.88
214-44	2-3/4													
A 215	75 mm													
215-47	2-15/16	4.0157	3.4646	0.6890	0.9409	0.0630	0.0157	0.0630	0.3346	0.2362	0.3465	3/8-24 UNF	0.63	0.39
215-48	3	102	88	17.5	23.9	1.6	0.4	1.6	8.5	6	8.8	M10 x 1.25	0.61	1.34
A 216	80 mm													
216-50	3-1/8	4.3307	3.7244	0.8110	1.0630	0.0630	0.0157	0.0630	0.4055	0.2756	0.4252	7/16 -20 UNF		
		110	94.6	20.6	27	1.6	0.4	1.6	10.3	7	10.8	M12 x 1.25		
A 217	85 mm													
217-52	3-1/4	4.6850	3.9764	0.8110	1.0630	0.0630	0.0157	0.0630	0.4055	0.3150	0.4252	7/16 -20 UNF		
		119	101	20.6	27	1.6	0.4	1.6	10.3	8	10.8	M12 x 1.25		
A 218	90 mm													
218-56	3-1/2	4.7244	4.1535	0.6889	0.9448	0.9842	0.0157	0.0630	0.3740	0.3150	0.4252	7/16 -20 UNF		
		120	105.5	17.5	24	2.4	0.4	1.6	9.5	8	10.8	M12 x 1.25		