

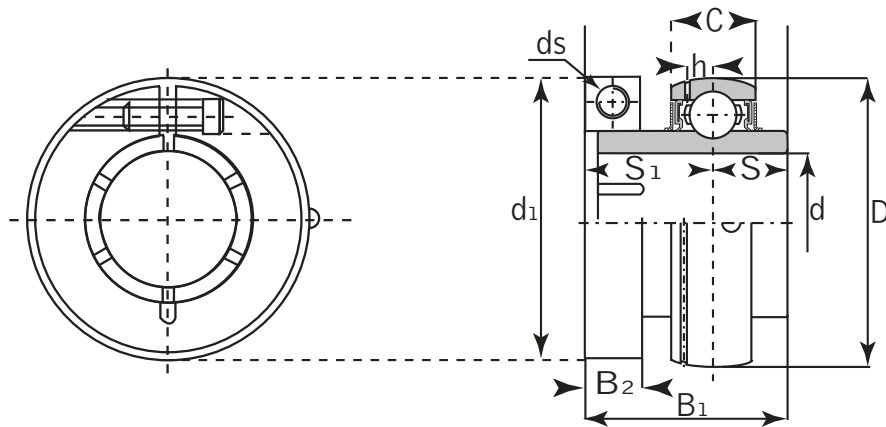

Bearing Insert

G RaB Loc Series - Normal Duty



GC

Unit No.	Shaft Dia. (inch / mm)	Dimensions (inch / mm)									Basic Load Rating lbf / N		Weight	
		d	D	d1	B1	B2	C	S	S1	h	ds	Dynamic	Static	kg
GC 204 204-12	20 mm 3/4	1.8504 47	1.7520 44.5	1.2795 32.5	0.3740 9.5	0.5906 15	0.500 12.7	0.7795 19.8	0.1575 4.0	8-32 x 5/8	2877 12800	1484 6600	0.22	0.48
GC 205 205-14 205-15 205-16	25 mm 7/8 15/16 1	2.0472 52	1.9370 49.2	1.4370 36.5	0.3740 9.5	0.6692 17	0.5630 14.3	0.8740 22.2	0.1654 4.2	8-32 x 5/8	3147 14000	1753 7800	0.35	0.77
GC 206 206-18 206-19 206-20	30 mm 1-1/8 1-3/8 1-1/4	2.4409 62	2.1890 55.6	1.5630 39.7	0.3740 9.5	0.7087 18	0.6260 15.9	0.9370 23.8	0.1890 4.8	8-32 x 5/8	4361 19400	2518 11200	0.50	1.10
GC 207 207-20 207-21 207-22 207-23	35 mm 1-1/4 1-5/16 1-3/8 1-7/16	2.8346 72	2.5590 65	1.7520 44.5	0.4370 11.1	0.7480 19	0.6890 17.5	1.0630 27.0	0.2126 5.4	10-24 x 3/4	5755 25600	3417 15200	0.66	1.45
GC 208 208-24 208-25	40 mm 1-1/2 1-9/16	3.1496 80	2.6890 68.3	2.000 50.8	0.4370 11.1	0.8661 22	0.7480 19.0	1.2520 31.8	0.2323 5.9	10-24 x 3/4	7328 32600	4551 19800	0.81	1.78
GC 209 209-26 209-27 209-28	45 mm 1-5/8 1-11/16 1-3/4	3.3464 85	2.9370 74.6	2.000 50.8	0.4370 11.1	0.8661 22	0.7480 19.0	1.2520 31.8	0.2402 6.1	10-24 x 3/4	4878 32700	4586 20400	0.83	1.83
GC 210 210-30 210-31 210-32	50 mm 1-7/8 1-15/16 2	3.5433 90	3.3740 85.7	2.0945 53.2	0.5630 14.3	0.8661 22	0.7480 19.0	1.3425 34.1	0.2559 6.5	1/4-20 x 1	7868 35000	5193 23100	1.09	2.40
GC 211 211-32 211-34 211-35	55 mm 2 2-1/8 2-3/16	3.9370 100	3.6220 92	2.2520 57.2	0.5630 14.3	0.9449 24	0.8740 22.2	1.3740 34.9	0.2795 7.1	1/4-20 x 1	9734 43300	6564 29200	1.32	2.91
GC 212 212-36 212-38 212-39	60 mm 2-1/4 2-3/8 2-7/16	4.3307 110	4.1338 105	2.6260 66.7	0.6890 17.5	1.0236 26	1.000 25.4	1.6260 41.3	0.2992 7.6	5/16-18 x 1	10723 47700	7396 32900	1.95	4.30