

Tapered Roller Bearings

Metric Series

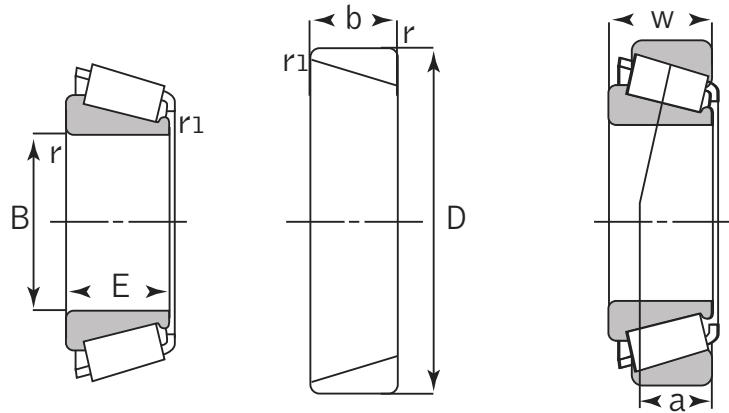

32300

Ass'y No.	Cone Bore	Cup O.D.	Bearing W.	Cone W.	Cup W.	Max. Shaft fillet Rad.	Max. Hang. Fillet Rad.	Weight (lbs)
	(mm)	(mm)	(mm)	(mm)	(mm)	(mm)	(mm)	
	B	D	W	E	b	R	r1	
32306	30	72	28.75	27	23	1.5	1.5	1.23
32307	35	80	32.75	31	25	2	1.5	1.67
32308	40	90	35.25	33	27	2	1.5	2.27
32309	45	100	38.25	36	30	2	1.5	3.01
32310	50	110	42.25	40	33	2.5	2	4.05
32311	55	120	45.5	43	35	2.5	2	5.15
32312	60	130	48.5	46	37	3	2.5	6.38
32313	65	140	51	48	39	3	2.5	7.79
32314	70	150	54	51	42	3	2.5	9.44
32316	80	170	61.5	58	48	3	2.5	13.90
32317	85	180	63.5	60	49	4	3	15.99

33100

Ass'y No.	Cone Bore	Cup O.D.	Bearing W.	Cone W.	Cup W.	Max. Shaft fillet Rad.	Max. Hang. Fillet Rad.	Weight (lbs)
	(mm)	(mm)	(mm)	(mm)	(mm)	(mm)	(mm)	
	B	D	W	E	b	R	r1	
33110	50	85	26	26	20	1.5	1.5	1.30
33111	55	95	30	30	23	1.5	1.5	1.87
33112	60	100	30	30	23	1.5	1.5	2.00
33113	65	110	34	34	26.5	1.5	1.5	2.75
33114	70	120	37	37	29	2	1.5	3.70
33115	75	125	37	37	29	2	1.5	3.89
33116	80	130	37	37	29	2	1.5	4.14
33117	85	140	41	41	32	2.5	2	5.46
33118	90	150	45	45	35	2.5	2	6.97