



Our Warranty, Your Satisfaction.

Since 2001, GRB Bearings, a 100% Canadian family owned company, has been a successful bearing supplier to distributors and OEMs across Canada. Our bearings are mainly imported from carefully selected manufacturers in China, and are made according to the international "ISO" quality control system, and under the minimum "ABEC 1" precision standard. Our confidence in our product is such, that we offer the best warranty in the industry.

If you are not totally satisfied with the quality of the bearings imported and manufactured under license for GRB, we will take them back (some conditions apply).

We are making it our duty to offer quality products to our customers; however, if an item happens to be defective, we will replace the product under the following conditions:

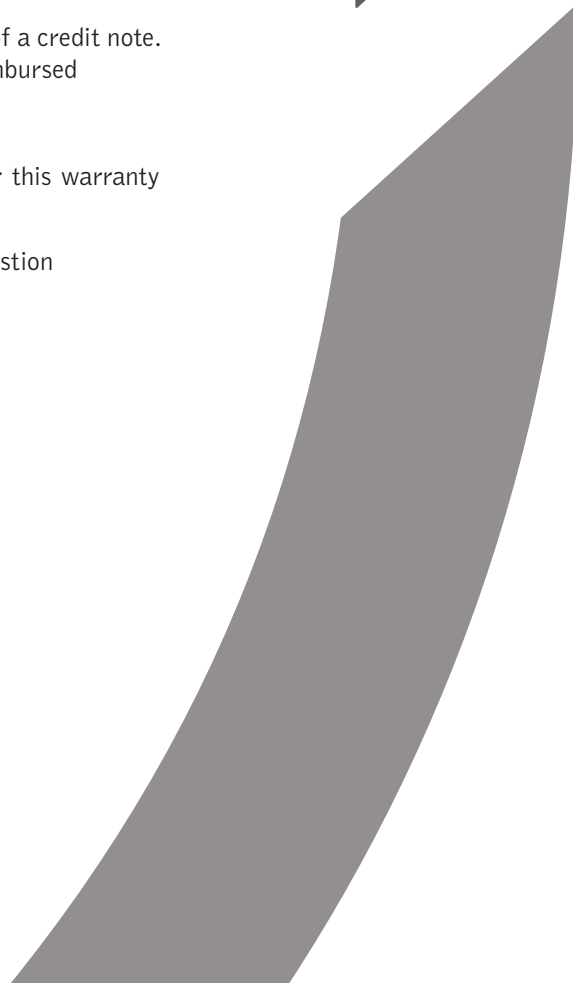
- The warranty is limited to the replacement or, at our discretion, the emission of a credit note. No other claims such as labour, loss or damage will be accepted and/or reimbursed
 - The warranty is limited to 90 days from date of invoice
 - Abusive usage, improper installation and/or inadequate maintenance render this warranty null and void
 - GRB reserves the right to verify the proper installation of the material in question
 - All parts must be returned prepaid to GRB
- 



LEGAL NOTICE

Force Majeure

GRB, our employees and/or agents take no responsibility for loss or damage occasioned by delay in delivery or inability to deliver, whether these events are caused by us, or arising from circumstances beyond our control such as acts of God, fire, accidents, strike, lockouts and/or any other similar causes.

Disclaimer

We've taken the greatest care to insure the accuracy of the information contained in this catalog but GRB will not accept liability for any errors or omissions. Products presented in this catalog are not necessarily available from stock. Please contact GRB's sales representative for availability. The structure and technical data shown in this catalog are those being used at the time of publication and GRB reserves the right to make changes without notice. The information listed in this catalog is for reference only. Rest assured that any comment and suggestion will be considered with great care.

**Some sizes may not be available at the time of your order or might require a minimum quantity.
Please check with your representative before making a definitive selection.**

Other products available

- Ball Bearings, Metric & Inch Sizes
- Spherical Plain Bearings
- Rod Ends
- Needle Bearings
- Roller Bearings
- Cam Followers
- Tapered Roller Bearings
- Thrust Bearings
- Pillow Blocks & Inserts
- Conveyor Bearings

And more!

Visit our website at **www.GRBBearings.com** for up to date information!

TABLE OF CONTENTS



Ball Bearings	4
Metric Series	5-6
Flanged Metric Series.....	7-8
Inch Series SSR, SSFR, SSR-EE, SSFR-EE	9
Single Row Radial Ball Bearings	
Inch Series SS 1600	10
Series SS 6000 & SS 6200	11
Series SS 6300	12
Series SS 6800 & SS 6900	13
Pillow Blocks	14
SSUCP	15
SSUCFL	16
SSUCF	17
SSUCPA_A.....	18
SSUCFB	19
SSUCST	20
SSUCHA	21
SSBSPP (Housing Pillow Block) & SSBSBF (Housing Round Flange Units)	22
SSBSPFT (Housing Flange Units) & SSBSPL (Oval Flange Units)	23
Ball Bearing Inserts	24
SUC Series	24
SHC Series (Eccentric Collar Series)	25
SSER Series	26
SSB & SAA Series	27
Thermoplastic Housing	28
SUCTP 200	29
SUCTF 200	30
SUCTFL 200	31
Rod Ends	32
Female Rod Ends (SFR_T & SFL_T Series)	33
Male Rod Ends (SMR_T & SML_T Series)	34
Spherical Plain Bearings with PTFE Liner (SCOM_T)	35
Shaft Collar	36
Solid Type Shaft Collar (SCSS Series)	37
Two Piece Shaft Collar (2SCSS Series)	38
Engineering	39
Clearance	40-41
Fit Charts	42-45
Bearing Tolerance	46-49
Conversion Charts	50-51
Grease Charts	52
Maximum Set Screw Torque for Stainless Steel Inserts	52



Ball Bearing Series

Stainless Steel

Metric Series

Flanged Metric Series

Inch Series SSR. SSRF. SSR-EE. SSFR-EE

Inch Series SS 1600

SS 6000

SS 6200

SS 6300

SS 6800

SS 6900



Bearing Material

AISI 440C stainless steel for inner and outer rings and balls.

Retainers

AISI 304 stainless steel 2 piece ribbon or crown type.

Crown type retainers are common in miniature and thin section bearings.

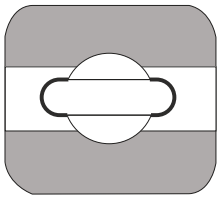

Ribbon

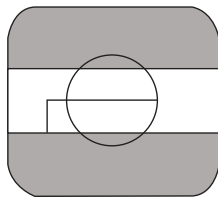

Crown

Closures

AISI 304 stainless steel shields available on most sizes. Since shields make no contact with the inner ring, torque does not increase. Neoprene bonded to a metal washer. The seal lips rub against the inner ring providing an effective seal against smaller particles such as dust and moisture. Torque increases notably, reducing operating speed.

Miniature & Instrument Ball Bearings

Stainless Steel - Metric Series

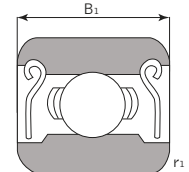
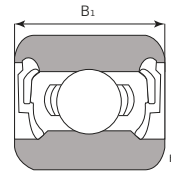
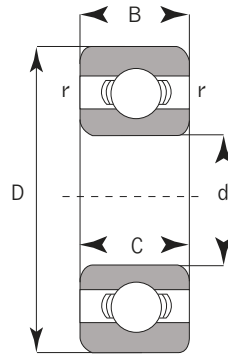

Open

2RS

ZZ

Unit No.	Bore (mm)	Outer Diameter (mm)	Width (mm)		Radius (mm)	Basic Load Rating (lbs)		Weight (lbs)
	d		D	Open B		2RS / ZZ B1	Dynamic Cr	
SS 681	1	3	1	-	0.05	14	4	0.001
SSMR 31	1	3	1.5	-	0.05	14	4	0.001
SS 691	1	4	1.6	-	0.10	19	6	0.001
SSMR 41X	1.2	4	1.8	2.5	0.10	19	6	0.001
SS 681X	1.5	4	1.2	2	0.05	16	5	0.001
SS 691X	1.5	5	2	2.6	0.15	23	8	0.001
SS 601X	1.5	6	2.5	3	0.15	44	17	0.001
SS 682	2	5	1.5	2.3	0.08	23	8	0.001
SSMR 52	2	5	2	2.5	0.10	30	8	0.001
SS 692	2	6	2.3	3	0.15	44	17	0.001
SSMR 62	2	6	2.5	2.5	0.15	48	17	0.001
SSMR 72	2	7	2.5	3	0.15	52	20	0.001
SS 602	2	7	2.8	3.5	0.15	53	22	0.001
SS 682X	2.5	6	1.8	2.6	0.08	28	11	0.001
SS 692X	2.5	7	2.5	3.5	0.15	53	22	0.001
SSMR 82X	2.5	8	2.5	-	0.20	51	18	0.001
SS 602X	2.5	8	2.8	4	0.15	51	18	0.001
SSMR 63	3	6	2	2.5	0.10	28	11	0.001
SS 683	3	7	2	3	0.10	53	22	0.001
SSMR 83	3	8	2.5	3	0.15	51	18	0.001
SS 693	3	8	3	4	0.15	51	18	0.001
SSMR 93	3	9	2.5	4	0.20	56	23	0.001
SS 603	3	9	3	5	0.15	79	32	0.002
SS 623	3	10	4	4	0.15	79	32	0.003
SS 633	3	13	5	5	0.20	213	74	0.005
SSMR 74	4	7	2	2.5	0.10	46	19	0.001
SSMR 84	4	8	2	3	0.15	70	25	0.001
SS 684	4	9	2.5	4	0.10	79	32	0.001
SSMR 104	4	10	3	4	0.20	79	32	0.002
SS 694	4	11	4	4	0.15	98	43	0.004
SS 604	4	12	4	4	0.20	134	58	0.005
SS 624	4	13	5	5	0.20	179	81	0.007
SS 634	4	16	5	5	0.30	240	105	0.013

Other sizes could be available upon request. Minimum quantity may apply.
 2RS stands for "Double Rubber Seals".
 ZZ stands for "Shielded".



Miniature & Instrument Ball Bearings

Stainless Steel - Metric Series

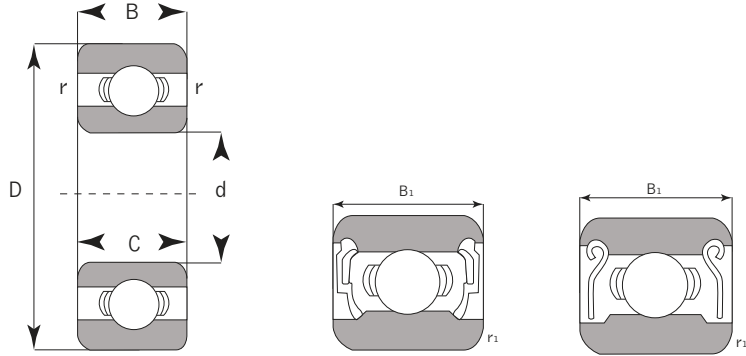

Open

2RS

ZZ

Unit No.	Bore (mm)	Outer Diameter (mm)	Width (mm)		Radius (mm)	Basic Load Rating (lbs)		Weight (lbs)
	d	D	Open B	2RS / ZZ B1	r, r1	Dynamic Cr	Static Cor	
SSMR 85	5	8	2	2.5	0.10	50	23	0.001
SSMR 95	5	9	2.5	3	0.15	90	35	0.001
SSMR 105	5	10	3	4	0.15	92	41	0.002
SSMR 115	5	11	3	4	0.15	98	43	0.002
SS 685	5	11	3	5	0.15	98	43	0.003
SS 695	5	13	4	4	0.20	150	68	0.005
SS 605	5	14	5	5	0.20	183	83	0.007
SS 625	5	16	5	5	0.30	240	105	0.010
SS 635	5	19	6	6	0.30	320	143	0.017
SSMR 106	6	10	2.5	3	0.15	98	43	0.001
SSMR 126	6	12	3	4	0.20	150	62	0.002
SS 686	6	13	3.5	5	0.15	150	68	0.004
SS 696	6	15	5	5	0.20	240	105	0.009
SS 606	6	17	6	6	0.30	240	105	0.013
SS 626	6	19	6	6	0.30	320	143	0.017
SS 636	6	22	7	7	0.30	536	210	0.030
SSMR 117	7	11	2.5	3	0.15	81	35	0.001
SSMR 137	7	13	3	4	0.20	158	66	0.003
SS 687	7	14	3.5	5	0.15	162	77	0.004
SS 697	7	17	5	5	0.30	188	90	0.012
SS 607	7	19	6	6	0.30	308	135	0.018
SS 627	7	22	7	7	0.30	464	218	0.024
SS 637	7	26	9	9	0.30	656	248	0.053
SSMR 128	8	12	2.5	3.5	0.15	92	43	0.001
SSMR 148	8	14	3.5	4	0.20	158	6	0.003
SS 688	8	16	4	5	0.20	248	120	0.007
SS 698	8	19	6	6	0.30	228	109	0.014
SSX 117	8	22	6	6	0.30	464	218	0.020
SS 608	8	22	7	7	0.30	464	218	0.024
SS 628	8	24	8	8	0.30	552	263	0.026
SS 638	8	28	9	9	0.30	810	330	0.056
SS 689	9	17	4	5	0.20	248	107	0.013
SS 699	9	20	6	6	0.30	422	173	0.017
SS 609	9	24	7	7	0.30	464	210	0.026
SS 629	9	26	8	8	0.30	632	300	0.040
SS 639	9	30	10	10	0.60	836	347	0.070

Other sizes could be available upon request. Minimum quantity may apply.

2RS stands for "Double Rubber Seals".

ZZ stands for "Shielded".

Miniature & Instrument Ball Bearings

Stainless Steel - Metric Flanged Series

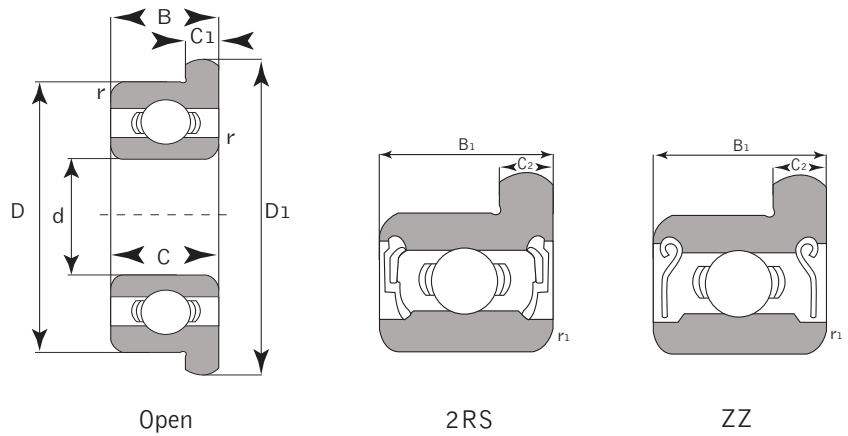

Unit No.	Bore (mm)	Outer Diameter (mm)		Flange Width		Width		Radius (mm)	Basic Load Rating (lbs)		Weight (lbs)
						Open (mm)	2RS / ZZ (mm)		Dynamic Cr	Static Cor	
						B	B1				
SSF 681	1	3	3.8	0.3	-	1	-	0.05	14.4	4	0.001
SSF 691	1	4	5.0	0.5	-	1.6	-	0.10	19.2	7	0.001
SSMF 41X	1.2	4	4.8	0.4	-	1.8	2.5	0.10	19.2	7	0.001
SSF 681X	1.5	4	5.0	0.4	-	1.2	2	0.05	16	5	0.001
SSF 691X	1.5	5	6.5	0.6	0.8	2	2.6	0.15	23	8	0.001
SSF 601X	1.5	6	7.5	0.6	0.8	2.5	3	0.15	44	17	0.001
SSF 682	2	5	6.1	0.5	0.6	1.5	2.3	0.08	23	8	0.001
SSMF 52	2	5	6.2	0.6	0.6	2	2.5	0.10	23	8	0.001
SSF 692	2	6	7.5	0.6	0.8	2.3	3	0.15	44	17	0.001
SSMF 62	2	6	7.2	0.6	-	2.5	2.5	0.15	44	17	0.001
SSMF 72	2	7	8.2	0.6	0.6	2.5	3	0.15	53	22	0.001
SSF 602	2	7	8.5	0.7	0.9	2.8	3.5	0.15	53	22	0.001
SSF 682X	2.5	6	7.1	0.5	0.8	1.8	2.6	0.08	28	11	0.001
SSF 692X	2.5	7	8.5	0.7	0.9	2.5	3.5	0.15	53	22	0.001
SSMF 82X	2.5	8	9.2	0.6	-	2.5	-	0.20	37	13	0.001
SSF 602X	2.5	8	9.5	0.7	0.9	2.8	4	0.15	51	18	0.001
SSMF 63	3	6	7.2	0.6	0.6	2	2.5	0.10	28	11	0.001
SSF 683	3	7	8.1	0.5	0.8	2	3	0.10	53	22	0.001
SSMF 83	3	8	9.2	0.6	-	2.5	-	0.15	51	18	0.001
SSF 693	3	8	9.5	0.7	0.9	3	4	0.15	51	18	0.001
SSMF 93	3	9	10.2*	0.6	0.8	2.5	4	0.20	79	32	0.001
SSF 603	3	9	10.5	0.7	-	3	-	0.15	79	32	0.002
SSF 623	3	10	11.5	1	1	4	4	0.15	79	32	0.004
SSMF 74	4	7	8.2	0.6	0.6	2	2.5	0.10	46	19	0.001
SSMF 84	4	8	9.2	0.6	0.6	2	3	0.15	6	25	0.001
SSF 684	4	9	10.3	0.6	1	2.5	4	0.10	79	32	0.001
SSMF 104	4	10	11.2*	0.6	0.8	3	4	0.20	79	32	0.002
SSF 694	4	11	12.5	1	1	4	4	0.15	98	43	0.004
SSF 604	4	12	13.5	1	1	4	4	0.20	134	58	0.005
SSF 624	4	13	15	1	1	5	5	0.20	179	81	0.006
SSF 634	4	16	18	1	1	5	5	0.30	240	105	0.012

Other sizes could be available upon request. Minimum quantity may apply.

*Flange Diameter 0.4mm greater for shielded bearings.

2RS stands for "Double Rubber Seals".

ZZ stands for "Shielded".



Miniature & Instrument Ball Bearings

Stainless Steel - Metric Flanged Series

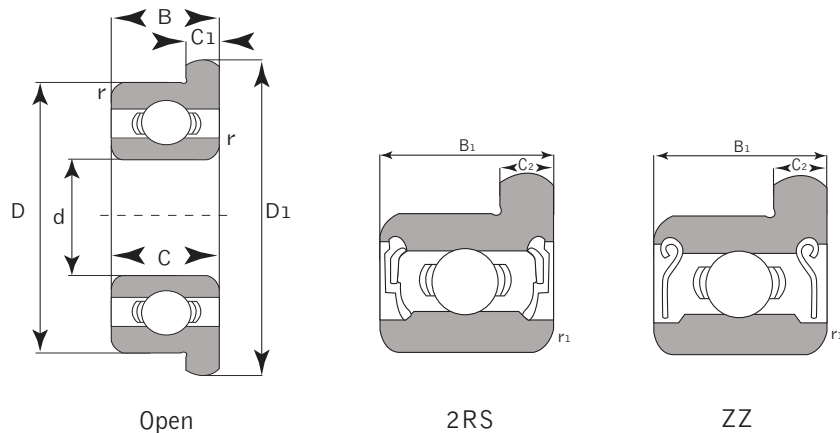

Unit No.	Bore (mm)	Outer Diameter (mm)		Flange Width		Width		Radius (mm)	Basic Load Rating (lbs)		Weight (lbs)
						Open (mm)	2RS / ZZ (mm)		Dynamic Cr	Static Cor	
	d	D	D 1	C1	C2	B	B1	r, r1			
SSMF 85	5	8	9.2	0.6	0.6	2	2.5	0.10	50	23	0.001
SSMF 95	5	9	10.2	0.6	0.6	2.5	3	0.15	90	35	0.001
SSMF 105	5	10	11.2*	0.6	0.8	3	4	0.15	92	41	0.002
SSMF 115	5	11	12.6	-	0.8	-	4	0.15	98	43	0.002
SSF 685	5	11	12.5	0.8	1	3	5	0.15	98	43	0.002
SSF 695	5	13	15	1	1	4	4	0.20	150	68	0.005
SSF 605	5	14	16	1	1	5	5	0.20	183	83	0.007
SSF 625	5	16	18	1	1	5	5	0.30	240	105	0.017
SSF 635	5	19	22	1.5	1.5	6	6	0.30	320	143	0.018
SSMF 106	6	10	11.2	0.6	0.6	2.5	3	0.15	98	43	0.001
SSMF 126	6	12	13.2*	0.6	0.8	3	4	0.20	150	62	0.002
SSF 686	6	13	15	1	1.1	3.5	5	0.15	150	68	0.004
SSF 696	6	15	17	1.2	1.2	5	5	0.20	240	105	0.009
SSF 606	6	17	19	1.2	1.2	6	6	0.30	240	105	0.013
SSF 626	6	19	22	1.5	1.5	6	6	0.30	320	143	0.018
SSMF 117	7	11	12.2	0.6	0.06	2.5	3	0.15	81	35	0.001
SSMF 137	7	13	14.2*	0.6	0.8	3	4	0.20	158	66	0.003
SSF 687	7	14	16	1	1.1	3.5	5	0.15	162	77	0.005
SSF 697	7	17	19	1.2	1.2	5	5	0.30	188	90	0.011
SSF 607	7	19	22	1.5	1.5	6	6	0.30	308	135	0.017
SSF 627	7	22	25	1.5	1.5	7	7	0.30	464	218	0.028
SSMF 128	8	12	13.2*	0.6	0.8	2.5	3.5	0.15	92	43	0.001
SSMF 148	8	14	15.6	0.8	0.8	3.5	4	0.20	158	66	0.004
SSF 688	8	16	18	1	1.1	4	5	0.20	248	120	0.007
SSF 698	8	19	22	1.5	1.5	6	6	0.30	228	109	0.016
SSF 608	8	22	25	1.5	1.5	7	7	0.30	464	218	0.026
SSF 689	9	17	19	1	1.1	4	5	0.20	248	107	0.007
SSF 699	9	20	23	1.5	1.5	6	6	0.30	422	173	0.018
SSF 609	9	24	27	1.5	1.5	7	7	0.30	464	210	0.020

Other sizes could be available upon request. Minimum quantity may apply.

*Flange Diameter 0.4mm greater for shielded bearings.

2RS stands for "Double Rubber Seals".

ZZ stands for "Shielded".

Miniature & Instrument Ball Bearings

Stainless Steel - Inch Series SSR, SSFR, SSR-E, SSFR-E

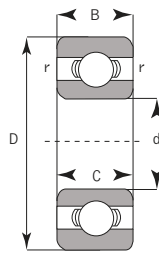

Open

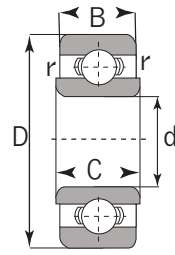

Open
Extended

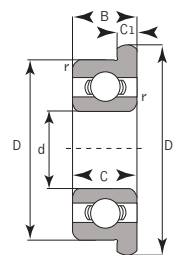

Flanged

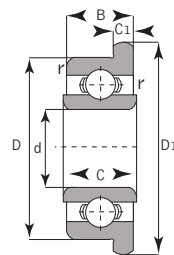

Flanged
Extended

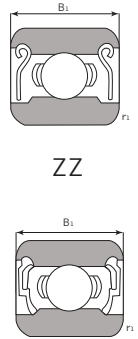

ZZ

2RS

Unit No.	Bore d		Outer Diameter D		Width				Flange Dimensions open		Radius inch r	Basic Load Rating Rating lbs		Weight lbs
	fract.	inch	fract.	inch	B / B1 - inch		C - inch		D1	C1		Dynamic Cr	Static Cor	
					open	2RS / ZZ	open	2RS / ZZ						
SSR 09	1/25	0.0400	1/8	0.2500	0.0469	-	-	-	-	-	0.004	18	5	0.001
SSR 0	3/64	0.0469	5/32	0.1562	0.0625	0.0937	0.0937	0.1250	0.203	0.013	0.004	29	8	0.001
SSR 1	-	0.0550	3/16	0.1875	0.0781	0.1094	0.1094	0.1406	0.234	0.023	0.004	34	10	0.001
SSR 1-4	5/64	0.0781	1/4	0.2500	0.0937	0.1406	0.1250	0.1719	0.296	0.023	0.004	50	15	0.001
SSR 133	3/32	0.0937	3/16	0.1875	0.0625	0.0937	0.0937	0.1250	0.234	0.018	0.004	22	7	0.001
SSR 1-5	3/32	0.0937	5/16	0.3125	0.1094	0.1406	0.1406	0.1719	0.359	0.023	0.006	77	26	0.001
SSR 144	1/8	0.1250	1/4	0.2500	0.0937	0.1094	0.1250	0.1406	0.296	0.023	0.004	51	17	0.001
SSR 2-5	1/8	0.1250	5/16	0.3125	0.1094	0.1406	0.1406	0.1719	0.359	0.023	0.004	21	30	0.002
SSR 2-6	1/8	0.1250	3/8	0.3750	0.1094	0.1406	0.1406	0.1719	0.422	0.023	0.006	35	38	0.002
SSR 2	1/8	0.1250	3/8	0.3750	0.1562	0.1562	0.1875	0.1875	0.440	0.030	0.012	35	38	0.003
SSR 2A	1/8	0.1250	1/2	0.5000	0.1719	0.1719	-	-	-	-	0.012	46	67	0.007
SSR 155	5/32	0.1562	5/16	0.3125	0.1094	0.1250	0.1406	0.1562	0.359	0.023	0.004	61	23	0.001
SSR 156	3/16	0.1875	5/16	0.3125	0.1094	0.1250	0.1406	0.1562	0.359	0.023	0.004	71	24	0.001
SSR 166	3/16	0.1875	3/8	0.3750	0.1250	0.1250	0.1562	0.1562	0.422	0.023	0.004	128	45	0.002
SSR 3	3/16	0.1875	1/2	0.5000	0.1562	0.1960	0.2272	0.2272	0.565	0.042	0.012	236	83	0.005
SSR 3A	3/16	0.1875	5/8	0.6250	0.1960	0.1960	-	-	-	-	0.012	236	83	0.006
SSR 168	1/4	0.2500	3/8	0.3750	0.1250	0.1250	0.1562	0.1562	0.422	0.023	0.004	48	23	0.001
SSR 188	1/4	0.2500	1/2	0.5000	0.1250	0.1875	0.1562	0.2188	0.547	0.023	0.006	149	63	0.004
SSR 4	1/4	0.2500	5/8	0.6250	0.1960	0.1960	0.2272	0.2272	0.690	0.042	0.012	268	104	0.010
SSR 4A	1/4	0.2500	3/4	0.7500	0.2188	0.2812	-	-	-	-	0.016	420	149	0.017
SSR 1810	5/16	0.3125	1/2	0.5000	0.1562	0.1562	0.1875	0.1875	0.5470	0.031	0.005	94	43	0.001
SSR 1038	3/8	0.3750	5/8	0.6250	0.1562	0.1562	-	-	-	-	0.010	150	69	0.001
SSR 1238	3/8	0.3750	3/4	0.7500	0.1960	0.1960	-	-	-	-	0.010	308	142	0.001
SSR 6	3/8	0.3750	7/8	0.8750	0.2188	0.2812	-	-	0.969	0.062	0.016	596	236	0.024
SSR 1212	1/2	0.5000	3/4	0.7500	0.1562	0.1562	-	-	-	-	0.010	160	86	0.001
SSR 1412	1/2	0.5000	7/8	0.8750	0.2188	0.2812	-	-	-	-	0.010	338	167	0.001
SSR 8	1/2	0.5000	1-1/8	1.1250	0.2500	0.3125	-	-	1.225	0.062	0.016	918	401	0.039
SSR 1458	5/8	0.6250	7/8	0.8750	0.1562	0.1562	-	-	-	-	0.010	162	98	0.001
SSR 10	5/8	0.6250	1-3/8	1.3750	0.2812	0.3438	-	-	-	-	0.031	1078	551	0.081
SSR 1634	3/4	0.7500	1	1.0000	0.1562	0.1562	-	-	-	-	0.010	173	104	0.001
SSR 1834	3/4	0.7500	1-1/8	1.1250	0.2812	0.2812	-	-	-	-	0.016	180	116	0.001
SSR 12	3/4	0.7500	1-5/8	1.6250	0.3125	0.4375	-	-	-	-	0.031	1416	764	0.104
SSR 14	7/8	0.8750	1-7/8	1.8750	0.3750	0.5000	-	-	-	-	0.031	1809	987	0.157
SSR 16	1	1.0000	2	2.0000	0.3750	0.5000	-	-	-	-	0.031	1809	987	0.187
SSR 18	1-1/8	1.1250	2-1/8	2.1250	0.3750	0.5000	-	-	-	-	0.031	1720	1055	0.198
SSR 20	1-1/4	1.2500	2-1/4	2.2500	0.3750	0.5000	-	-	-	-	0.031	2378	1394	0.209
SSR 22	1-3/8	1.3750	2-1/2	2.5000	0.4375	0.5625	-	-	-	-	0.031	2205	1433	0.232
SSR 24	1-1/2	1.5000	2-5/8	2.6250	0.4375	0.5626	-	-	-	-	0.031	2325	1563	0.309

Other sizes could be available upon request. Minimum quantity may apply.

"F" stands for "Flanged" as in SSFR.

"EE" stands for "Extended Inner Ring" as in SSR-EE and SSFR-EE.

2RS stands for "Double Rubber Seals" / ZZ stands for "Shielded"



Single Row Radial Ball Bearings

Stainless Steel - Inch Series SS 1600

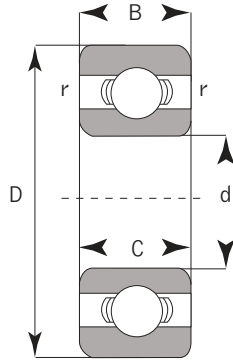

Open

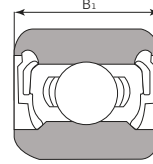

2RS

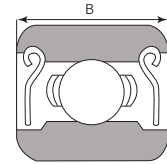

ZZ

Unit No.	Bore d		Outer Diameter D		Width B		Radius inch	Basic Load Rating Rating lbs		Weight lbs
	fract.	inch	fract.	inch	fract.	inch	r	Dynamic Cr	Static Cor	
SS 1601	3/16	0.1875	11/16	0.6875	1/4*	0.2500*	0.012	280	125	0.012
SS 1602	1/4	0.2500	11/16	0.6875	1/4*	0.2500*	0.012	280	125	0.013
SS 1603	5/16	0.3125	7/8	0.8750	9/32**	0.2812**	0.012	549	233	0.023
SS 1604	3/8	0.3750	7/8	0.8750	9/32**	0.2812**	0.015	549	233	0.021
SS 1605	5/16	0.3125	29/32	0.9062	5/16	0.3125	0.012	580	239	0.032
SS 1606	3/8	0.3750	29/32	0.9062	5/16	0.3125	0.015	580	239	0.030
SS 1607	7/16	0.4375	29/32	0.9062	5/16	0.3125	0.015	580	239	0.035
SS 1614	3/8	0.3750	1-1/8	1.1250	3/8	0.3750	0.025	708	376	0.077
SS 1615	7/16	0.4375	1-1/8	1.1250	3/8	0.3750	0.025	708	376	0.071
SS 1616	1/2	0.5000	1-1/8	1.1250	3/8	0.3750	0.025	708	376	0.066
SS 1620	7/16	0.4375	1-3/8	1.3750	7/16	0.4375	0.025	830	470	0.105
SS 1621	1/2	0.5000	1-3/8	1.3750	7/16	0.4375	0.025	830	470	0.106
SS 1622	9/16	0.5625	1-3/8	1.3750	7/16	0.4375	0.025	830	470	0.101
SS 1623	5/8	0.6250	1-3/8	1.3750	7/16	0.4375	0.025	830	470	0.088
SS 1628	5/8	0.6250	1-5/8	1.6250	1/2	0.5000	0.025	1478	791	0.159
SS 1630	3/4	0.7500	1-5/8	1.6250	1/2	0.5000	0.025	1478	791	0.143
SS 1633	5/8	0.6250	1-3/4	1.7500	1/2	0.5000	0.025	1478	791	0.203
SS 1635	3/4	0.7500	1-3/4	1.7500	1/2	0.5000	0.025	1478	791	0.187
SS 1638	3/4	0.7500	2	2.0000	9/16	0.5625	0.035	1566	874	0.265
SS 1640	7/8	0.8750	2	2.0000	9/16	0.5625	0.035	1566	874	0.247
SS 1641	1	1.0000	2	2.0000	9/16	0.5625	0.035	1566	874	0.221
SS 1652	1-1/8	1.1250	2-1/2	2.5000	5/8	0.6250	0.035	2074	1301	0.463
SS 1654	1-1/4	1.2500	2-1/2	2.5000	5/8	0.6250	0.035	2074	1301	0.419
SS 1657	1-1/4	1.2500	2-9/16	2.5625	11/16	0.6875	0.035	2690	1683	0.474
SS 1658	1-5/16	1.3125	2-9/16	2.5625	11/16	0.6875	0.035	2690	1683	0.441

Other sizes could be available upon request. Minimum quantity may apply.

*Width 5/16 inch for RS, 2RS

**Width 11/32 inch for RS, 2RS, Z & ZZ

2RS stands for "Double Rubber Seals".

ZZ stands for "Shielded".

Single Row Radial Ball Bearings

Stainless Steel - Series SS 6000 & SS 6200

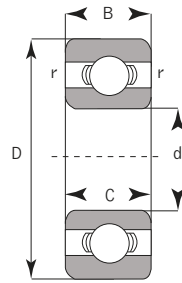

Open

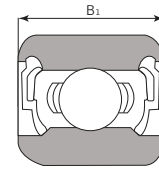

2RS

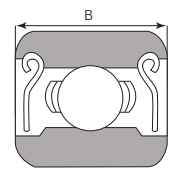

ZZ

SS 6000

Unit No.	Bore d		Outer Diameter D		Width B		Radius r		Basic Load Rating Rating lbs		Weight lbs
	mm	inch	mm	inch	mm	inch	mm	inch	Dynamic Cr	Static Cor	
SS 6000	10	0.3937	26	1.0236	8	0.3150	0.5	0.020	824	330	0.042
SS 6001	12	0.4724	28	1.1024	8	0.3150	0.5	0.020	920	405	0.049
SS 6002	15	0.5906	32	1.2598	9	0.3543	0.5	0.020	1008	476	0.066
SS 6003	17	0.6693	35	1.3780	10	0.3937	0.5	0.020	1224	566	0.086
SS 6004	20	0.7874	42	1.6535	12	0.4724	1.0	0.039	1688	855	0.152
SS 6005	25	0.9843	47	1.8504	12	0.4724	1.0	0.039	1808	990	0.176
SS 6006	30	1.1811	55	2.1654	13	0.5118	1.5	0.059	2376	1395	0.256
SS 6007	35	1.3780	62	2.4409	14	0.5512	1.5	0.059	2880	1733	0.342
SS 6008	40	1.5748	68	2.6772	15	0.5906	1.5	0.059	3000	1943	0.423
SS 6009	45	1.7717	75	2.9528	16	0.6299	1.5	0.059	3760	2550	0.540
SS 6010	50	1.9685	80	3.1496	16	0.6299	1.5	0.059	3920	2813	0.575
SS 6011	55	2.1654	90	3.5433	18	0.7087	1.5	0.059	5080	3600	0.849
SS 6012	60	2.3622	95	3.7402	18	0.7087	2.0	0.079	5280	3900	0.915

SS 6200

Unit No.	Bore d		Outer Diameter D		Width B		Radius r		Basic Load Rating Rating lbs		Weight lbs
	mm	inch	mm	inch	mm	inch	mm	inch	Dynamic Cr	Static Cor	
SS 6200	10	0.3937	30	1.1811	9	0.3543	1.0	0.039	920	405	0.071
SS 6201	12	0.4724	32	1.2598	10	0.3937	1.0	0.039	1096	461	0.082
SS 6201-8	12.7	0.5000	32	1.2598	10	0.3937	1.0	0.039	1096	461	0.082
SS 6202	15	0.5906	35	1.3780	11	0.4331	1.0	0.039	1392	604	0.099
SS 6202-10	15.875	0.6250	35	1.3780	11	0.4331	1.0	0.039	1392	604	0.099
SS 6203	17	0.6693	40	1.5748	12	0.4724	1.0	0.039	1728	773	0.143
SS 6203-8	12.7	0.5000	40	1.5748	12	0.4724	1.0	0.039	1728	773	0.150
SS 6203-10	15.875	0.6250	40	1.5748	12	0.4724	1.0	0.039	1728	773	0.150
SS 6203-12	19.05	0.7500	40	1.5748	12	0.4724	1.0	0.039	1728	773	0.150
SS 6204	20	0.7874	47	1.8504	14	0.5512	1.5	0.059	2312	1125	0.234
SS 6204-12	19.05	0.7500	47	1.8504	14	0.5512	1.5	0.059	2312	1125	0.236
SS 6205	25	0.9843	52	2.0472	15	0.5906	1.5	0.059	2520	1328	0.282
SS 6205-16	25.4	1.0000	52	2.0472	15	0.5906	1.5	0.059	2520	1328	0.280
SS 6206	30	1.1811	62	2.4409	16	0.6299	1.5	0.059	3520	1905	0.439
SS 6207	35	1.3790	72	2.8346	17	0.6693	2.0	0.079	4600	2588	0.635
SS 6208	40	1.5748	80	3.1496	18	0.7087	2.0	0.079	5240	3000	0.807
SS 6209	45	1.7717	85	3.3465	19	0.7480	2.0	0.079	5880	3450	0.897
SS 6210	50	1.9685	90	3.5433	20	0.7874	2.0	0.079	6320	3900	1.02
SS 6211	55	2.1654	100	3.9370	21	0.8268	2.5	0.098	7800	4913	1.34
SS 6212	60	2.3622	110	4.3307	22	0.8661	2.5	0.098	9440	6113	1.73

Other sizes could be available upon request. Minimum quantity may apply.

2RS stands for "Double Rubber Seals".

ZZ stands for "Shielded".



Single Row Radial Ball Bearings

Stainless Steel - Series SS 6300

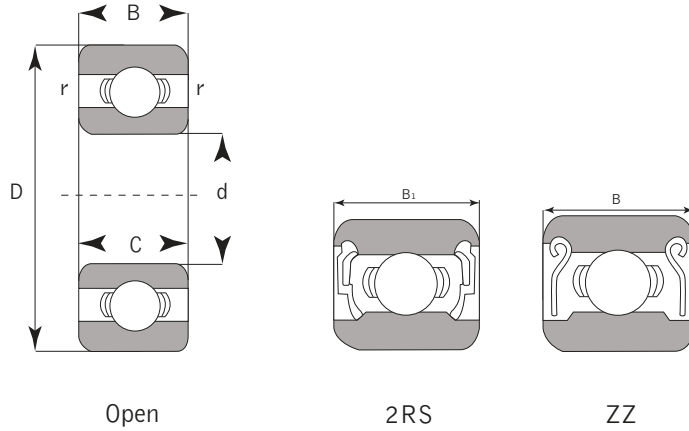
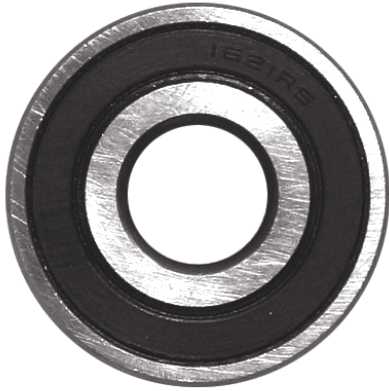

Unit No.	Bore d		Outer Diameter D		Width B		Radius r		Basic Load Rating Rating lbs		Weight lbs
	mm	inch	mm	inch	mm	inch	mm	inch	Dynamic Cr	Static Cor	
SS 6300	10	0.3937	35	1.3780	11	0.4331	1.0	0.039	1472	589	0.117
SS 6301	12	0.4724	37	1.4567	12	0.4724	1.5	0.059	1744	705	0.132
SS 6302	15	0.5906	42	1.6535	13	0.5118	1.5	0.059	2056	915	0.181
SS 6303	17	0.6693	47	1.8504	14	0.5512	1.5	0.059	2440	1103	0.254
SS 6304	20	0.7874	52	2.0472	15	0.5906	2.0	0.079	2880	1328	0.317
SS 6305	25	0.9843	62	2.4409	17	0.6693	2.0	0.079	3800	1845	0.511
SS 6306	30	1.1811	72	2.8346	19	0.7480	2.0	0.079	5360	2850	0.763
SS 6307	35	1.3780	80	3.1496	21	0.8268	2.5	0.098	6000	3225	1.01
SS 6308	40	1.5748	90	3.5433	23	0.9055	2.5	0.098	7320	4050	1.40
SS 6309	45	1.7717	100	3.9370	25	0.9843	2.5	0.098	9520	5400	1.84
SS 6310	50	1.9685	110	4.3307	27	1.0630	3.0	0.118	11120	6450	2.36
SS 6311	55	2.1654	120	4.7244	29	1.1417	3.0	0.118	12880	7575	3.02
SS 6312	60	2.3622	130	5.1181	31	1.2205	3.5	0.138	14720	8775	3.75

Other sizes could be available upon request. Minimum quantity may apply.

2RS stands for "Double Rubber Seals".

ZZ stands for "Shielded".

Single Row Radial Ball Bearings

Stainless Steel - Series SS 6800 & SS 6900

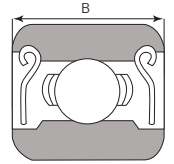
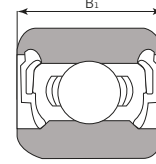
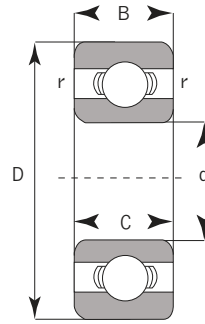

Open

2RS

ZZ

SS 6800

Unit No.	Bore d		Outer Diameter D		Width B		Radius r		Basic Load Rating Rating lbs		Weight	
	mm	inch	mm	inch	mm	inch	mm	inch	Dynamic Cr	Static Cor	kg	lbs
SS 6800	10	0.3937	19	0.7480	5	0.1969	0.5	0.019	328	156	0.005	0.011
SS 6801	12	0.4724	21	0.8268	5	0.1969	0.5	0.019	344	176	0.006	0.013
SS 6802	15	0.5906	24	0.9449	5	0.1969	0.5	0.019	372	212	0.007	0.015
SS 6803	17	0.6693	26	1.0236	5	0.1969	0.5	0.019	504	289	0.008	0.018
SS 6804	20	0.7874	32	1.2598	7	0.2756	0.5	0.019	720	416	0.019	0.042
SS 6805	25	0.9843	37	1.4567	7	0.2756	0.5	0.019	772	499	0.022	0.053
SS 6806	30	1.1811	42	1.6535	7	0.2756	0.5	0.019	848	611	0.026	0.055
SS 6807	35	1.3780	47	1.8504	7	0.2756	0.5	0.019	880	679	0.029	0.063
SS 6808	40	1.5748	52	2.0472	7	0.2756	0.5	0.019	912	739	0.033	0.072
SS 6809	45	1.7717	58	2.2835	7	0.2756	0.5	0.019	1135	953	0.040	0.088
SS 6810	50	1.9685	65	2.5591	7	0.2756	0.5	0.019	1184	1028	0.052	0.114
SS 6811	55	2.1654	72	2.8346	9	0.3543	0.5	0.019	1584	1365	0.083	0.182
SS 6812	60	2.3622	78	3.0709	10	0.3937	0.5	0.019	2064	1785	0.106	0.233

SS 6900

Unit No.	Bore d		Outer Diameter D		Width B		Radius r		Basic Load Rating Rating lbs		Weight	
	mm	inch	mm	inch	mm	inch	mm	inch	Dynamic Cr	Static Cor	kg	lbs
SS 6900	10	0.3937	22	0.8661	6	0.2362	0.5	0.020	484	214	0.009	0.020
SS 6901	12	0.4724	24	0.9449	6	0.2362	0.5	0.020	520	248	0.011	0.024
SS 6902	15	0.5906	28	1.1024	7	0.2756	0.5	0.020	736	345	0.016	0.035
SS 6903	17	0.6693	30	1.1811	7	0.2756	0.5	0.020	840	435	0.018	0.040
SS 6904	20	0.7874	37	1.4567	9	0.3543	0.5	0.020	1144	619	0.036	0.079
SS 6905	25	0.9843	42	1.6535	9	0.3543	0.5	0.020	1264	765	0.042	0.093
SS 6906	30	1.1811	47	1.8504	9	0.3543	0.5	0.020	1304	848	0.048	0.106
SS 6907	35	1.3780	55	2.1654	10	0.3937	1	0.039	2008	1253	0.074	0.163
SS 6908	40	1.5748	62	2.4409	12	0.4724	1	0.039	912	739	0.110	0.243
SS 6909	45	1.7717	68	2.6772	12	0.4724	1	0.039	2720	1898	0.128	0.282
SS 6910	50	1.9685	72	2.8346	12	0.4724	1	0.039	2800	2063	0.132	0.291
SS 6911	55	2.1654	80	3.1496	13	0.5118	1.5	0.059	2880	2235	0.180	0.397
SS 6912	60	2.3622	85	3.3465	13	0.5118	1.5	0.059	2960	2400	0.193	0.425

Other sizes could be available upon request. Minimum quantity may apply.
 2RS stands for "Double Rubber Seals".
 ZZ stands for "Shielded".



Pillow Blocks & Inserts

Stainless Steel

Pillow Blocks Series

SSUCP
SSUCFL
SSUCF
SSUCPA_A
SSUCFB
SSUCST
SSUCHA
SSBSPP
SSBSPF
SSBSPFT
SSBSPFL

Inserts Series

SUC
SSER
SSB
SSA
SHC

Main Purposes

These units are mainly used in the food and pharmaceutical industries, in applications sensitive to harsh environment, salt water or everywhere corrosion is a problem.

Pillow Blocks & Inserts Material

Our pillow blocks are made of AISI 304 stainless steel.
Our bearings are supplied with FDA approved Mobilgrease.
The inner and outer races and the balls are made of AISI 440C stainless steel.
The cages, flingers and grease fitting are made of AISI 304 stainless steel.

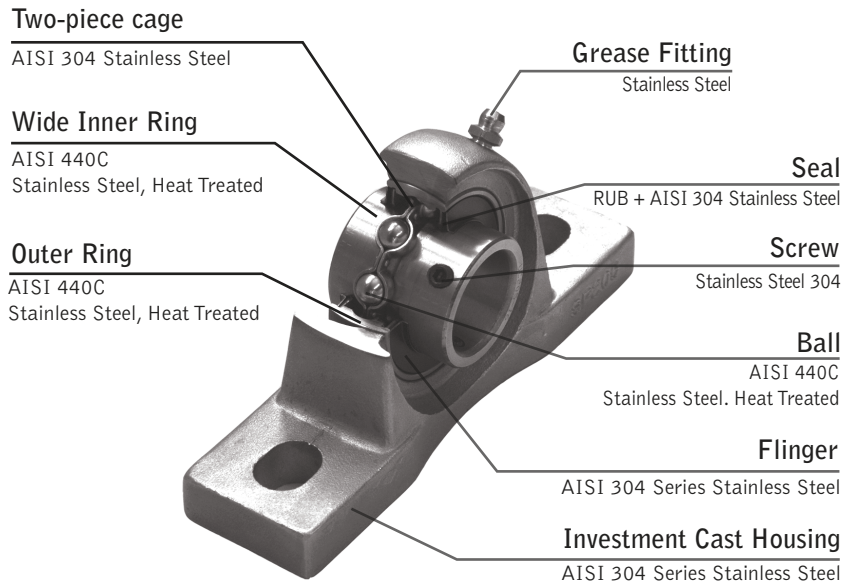

Pillow Blocks

Stainless Steel - SSUCP Series

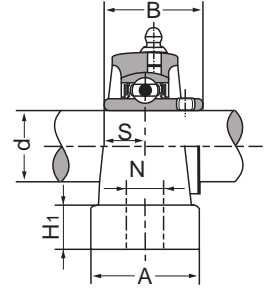
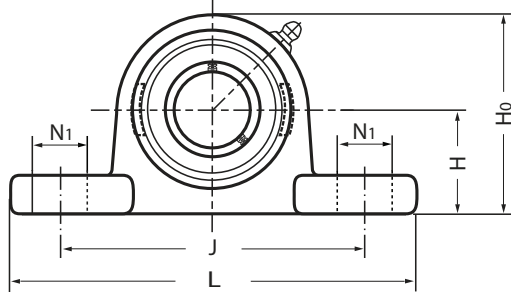

Also available with eccentric locking collar bearing

Unit No.	Shaft Dia. (inch / mm)	Dimensions (inch / mm)										Bolt Size	Bearing No.	Housing No.	Mass	
		d	H	L	J	A	N	N1	H1	H0	B				S	kg
SSUCP 201 201-8 202 202-10 203 204-12 204	12 mm 1/2 15 mm 5/8 17 mm 3/4 20 mm	1-5/16 33.3	5 127	3-3/4 95.3	1-1/2 38	1/2 13	5/8 16	9/16 14	2-7/16 62	1.2205 31.0	0.500 12.7	3/8 M10	SUC 201 201-8 202 202-10 203 204-12 204	SP 204	0.6	1.3
SSUCP 205-14 205-15 205 205-16	7/8 15/16 25 mm 1	1-7/16 36.5	5 1/2 140	4-1/8 104.8	1-1/2 38	1/2 13	5/8 16	19/32 15	2-25/32 71	1.3425 34.1	0.563 14.3	3/8 M10	SUC 205-14 205-15 205 205-16	SP 205	0.7	1.6
SSUCP 206-18 206 206-19 206-20	1-1/8 30 mm 1-3/16 1-1/4	1-11/16 42.9	6-1/2 165	4-3/4 120.7	1-7/8 48	21/32 17	25/32 20	21/32 17	3-9/32 83	1.5000 38.1	0.626 15.9	1/2 M14	SUC 206-18 206 206-19 206-20	SP 206	1.2	2.5
SSUCP 207-20 207-21 207-22 207 207-23	1-1/4 1-5/16 1-3/8 35 mm 1-7/16	1-7/8 47.6	6-9/16 167	5 127	1-7/8 48	21/32 17	25/32 20	23/32 18	3-21/32 93	1.6890 42.9	0.689 17.5	1/2 M14	SUC 207-20 207-21 207-22 207 207-23	SP 207	1.6	3.5
SSUCP 208-24 208-25 208	1-1/2 1-9/16 40 mm	1-15/16 49.2	7-1/4 184	5-13/32 137.3	2-1/8 54	21/32 17	25/32 20	23/32 18	3-21/32 98	1.9370 49.2	0.748 19.0	1/2 M14	SUC 208-24 208-25 208	SP 208	1.9	4.2
SSUCP 209-26 209-27 209-28 209	1-5/8 1-11/16 1-3/4 45 mm	2-1/8 54.0	7-15/32 190	5-3/4 146.1	2-1/8 54	21/32 17	25/32 20	25/32 20	4-3/16 106	1.9370 49.2	0.748 19.0	1/2 M14	SUC 209-26 209-27 209-28 209	SP 209	2.2	4.9
SSUCP 210-30 210-31 210 210-32	1-7/8 1-15/16 50 mm 2	2-1/4 57.2	8-1/8 206	6-1/4 158.8	2-3/8 60	25/32 20	29/32 23	13/16 21	4-1/2 114	2.0315 51.6	0.748 19.0	5/8 M16	SUC 210-30 210-31 210 210-32	SP 210	2.6	5.7
SSUCP 211-32 211-34 211 211-35	2 2-1/8 55 mm 2-3/16	2-1/2 63.5	8-5/8 219	6-23/32 170.7	2-3/8 60	25/32 20	29/32 23	29/32 23	4-31/32 126	2.1890 55.6	0.874 22.2	5/8 M16	SUC 211-32 211-34 211 211-35	SP 211	3.3	7.3
SSUCP 212-36 212 212-38 212-39	2-1/4 60 mm 2-3/8 2-7/16	2-3/4 69.8	9-1/2 241	7-1/4 184.2	2-3/4 70	25/32 20	29/32 23	31/32 25	5-7/16 138	2.5630 65.1	1.000 25.1	5/8 M16	SUC 212-36 212 212-38 212-39	SP 212	4.6	10.0

Other sizes could be available upon request. Minimum quantity may apply.
Please refer to page 52 for setscrew maximum torque informations.



Oval Flange Units

Stainless Steel - SSUCFL Series

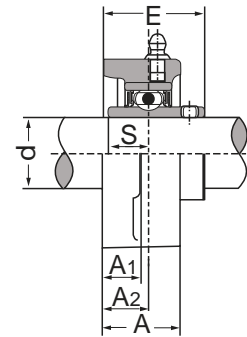
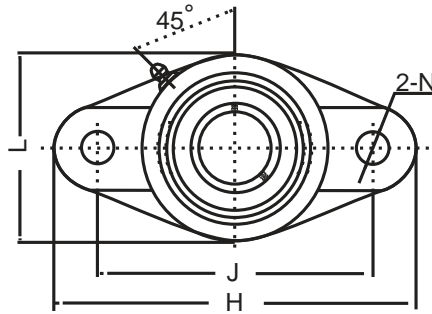

Also available with eccentric locking collar bearing

Unit No.	Shaft Dia. (inch / mm)	Dimensions (inch / mm)									Bolt Size	Bearing No.	Housing No.	Mass	
		d	H	J	A2	A1	A	N	L	E				S	kg
SSUCFL 201 201-8 202 202-10 203 204-12 204	12 mm 1/2 15 mm 5/8 17 mm 3/4 20 mm	4-7/16 113	3-35/64 90.1	19/32 15	7/16 11	1 25.4	15/32 12	2-3/8 60.3	1-5/16 33.3	0.500 12.7	3/8 M10	SUC 201 201-8 202 202-10 203 204-12 204	SFL 204	0.5	1.1
SSUCFL 205-14 205-15 205 205-16	7/8 15/16 25 mm 1	5-1/8 130	3-57/64 98.8	5/8 16	1/2 13	1-1/16 27.0	5/8 16	2-11/16 68.3	1-13/32 35.8	0.563 14.3	1/2 M14	SUC 205-14 205-15 205 205-16	SFL 205	0.6	1.3
SSUCFL 206-18 206 206-19 206-20	1-1/8 30 mm 1-3/16 1-1/4	5-13/16 148	4-39/64 117.1	45/64 18	1/2 13	1-7/32 31	5/8 16	3-5/32 80.2	1-37/64 40.2	0.626 15.9	1/2 M14	SUC 206-18 206 206-19 206-20	SFL 206	0.9	2.0
SSUCFL 207-20 207-21 207-22 207 207-23	1-1/4 1-5/16 1-3/8 35 mm 1-7/16	6-11/32 161	5-1/8 130.2	3/4 19	19/32 15	1-11/32 34.1	5/8 16	3-17/32 89.7	1-3/4 44.4	0.689 17.5	1/2 M14	SUC 207-20 207-21 207-22 207 207-23	SFL 207	1.2	2.6
SSUCFL 208-24 208-25 208	1-1/2 1-9/16 40 mm	6-7/8 175	5-43/64 144.1	53/64 21	19/32 15	1-13/32 35.7	5/8 16	3-15/16 100.0	2-1/64 51.2	0.748 19	1/2 M14	SUC 208-24 208-25 208	SFL 208	1.6	3.5
SSUCFL 209-26 209-27 209-28 209	1-5/8 1-11/16 1-3/4 45 mm	7-13/32 188	5-53/64 148.0	55/64 22	5/8 16	1-1/2 38.1	3/4 19	4-1/4 108.0	2-1/16 52.2	0.748 19	5/8 M16	SUC 209-26 209-27 209-28 209	SFL 209	1.9	4.2
SSUCFL 210-30 210-31 210 210-32	1-7/8 1-15/16 50 mm 2	7-3/4 197	6-3/16 157.2	55/64 22	5/8 16	1-9/16 39.7	3/4 19	4-17/32 115.1	2-5/32 54.6	0.748 19	5/8 M16	SUC 210-30 210-31 210 210-32	SFL 210	2.2	4.9
SSUCFL 211-32 211-34 211 211-35	2 2-1/8 55 mm 2-3/16	8-13/16 224	7-1/4 184.2	63/64 25	23/32 18	1-11/16 42.9	3/4 19	5-1/8 130.2	2-19/64 58.4	0.874 22.2	5/8 M16	SUC 211-32 211-34 211 211-35	SFL 211	3.1	6.8
SSUCFL 212-36 212 212-38 212-39	2-1/4 60 mm 2-3/8 2-7/16	9-27/32 250	7-61/64 202.0	1-9/64 29	23/32 18	1-7/8 47.6	29/32 23	5-1/2 139.7	2-45/64 68.7	1.000 25.4	3/4 M20	SUC 212-36 212 212-38 212-39	SFL 212	4.0	8.8

Other sizes could be available upon request. Minimum quantity may apply.
Please refer to page 52 for setscrew maximum torque informations.

Square Flange Units

Stainless Steel - SSUCF Series

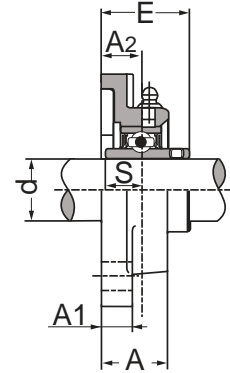
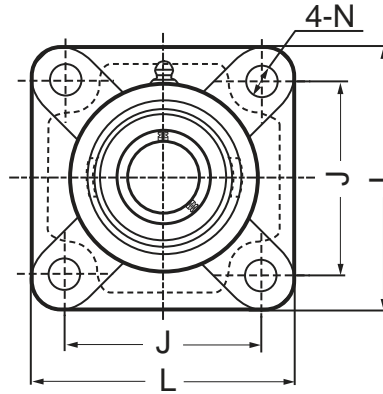

Also available with eccentric locking collar bearing

Unit No.	Shaft Dia. d (inch / mm)	Dimensions (inch / mm)								Bolt Size	Bearing No.	Housing No.	Mass	
		L	J	A2	A1	A	N	E	S				kg	lbs
SSUCF 201 201-8 202 202-10 203 204-12 204	12 mm 1/2 15 mm 5/8 17 mm 3/4 20 mm	3-3/8 86	2-33/64 63.9	19/32 15	7/16 11	1 25.5	15/32 12	1-5/16 33.3	0.500 12.7	3/8 M10	SUC 201 201-8 202 202-10 203 204-12 204	SF 204	0.7	1.5
SSUCF 205-14 205-15 205 205-16	7/8 15/16 25 mm 1	3-3/4 95	2-3/4 69.9	5/8 16	1/2 13	1-1/16 27.0	15/32 12	1-13/32 35.8	0.563 14.3	3/8 M10	SUC 205-14 205-15 205 205-16	SF 205	0.8	1.8
SSUCF 206-18 206 206-19 206-20	1-1/8 30 mm 1-3/16 1-1/4	4-1/4 108	3-17/64 82.9	45/64 18	1/2 13	1-7/32 31.0	15/32 12	1-37/64 40.2	0.626 15.9	3/8 M10	SUC 206-18 206 206-19 206-20	SF 206	1.0	2.2
SSUCF 207-20 207-21 207-22 207 207-23	1-1/4 1-5/16 1-3/8 35 mm 1-7/16	4-19/32 117	3-5/8 92.1	3/4 19	19/32 15	1-11/32 34.0	35/64 14	1-3/4 44.4	0.689 17.5	7/16 M12	SUC 207-20 207-21 207-22 207 207-23	SF 207	1.4	3.1
SSUCF 208-24 208-25 208	1-1/2 1-9/16 40 mm	5-1/8 130	4-1/64 102.0	53/64 21	19/32 15	1-13/32 36.0	5/8 16	2-1/64 51.2	0.748 19	1/2 M14	SUC 208-24 208-25 208	SF 208	1.8	4.0
SSUCF 209-26 209-27 209-28 209	1-5/8 1-11/16 1-3/4 45 mm	5-13/32 137	4-9/64 105.2	55/64 22	5/8 16	1-1/2 38.0	5/8 16	2-1/16 52.2	0.748 19	1/2 M14	SUC 209-26 209-27 209-28 209	SF 209	2.2	4.9
SSUCF 210-30 210-31 210 210-32	1-7/8 1-15/16 50 mm 2	5-5/8 143	4-3/8 111.1	55/64 22	5/8 16	1-9/16 40.0	5/8 16	2-5/32 54.6	0.748 19	1/2 M14	SUC 210-30 210-31 210 210-32	SF 210	2.4	5.3
SSUCF 211-32 211-34 211 211-35	2 2-1/8 55 mm 2-3/16	6-3/8 162	5-1/8 130.2	63/64 25	23/32 18	1-11/16 43.0	3/4 19	2-19/64 58.4	0.874 22.2	5/8 M16	SUC 211-32 211-34 211 211-35	SF 211	3.6	7.9
SSUCF 212-36 212 212-38 212-39	2-1/4 60 mm 2-3/8 2-7/16	6-7/8 175	5-5/8 142.9	1-9/64 29	23/32 18	1-7/8 48.0	3/4 19	2-45/64 68.7	1 25.4	5/8 M16	SUC 212-36 212 212-38 212-39	SF 212	4.4	9.7

Other sizes could be available upon request. Minimum quantity may apply.
Please refer to page 52 for setscrew maximum torque informations.



Tapped-Based Pillow Blocks

Stainless Steel - SSUCPA_A Series

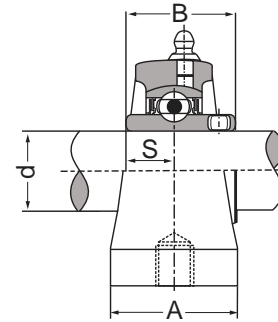
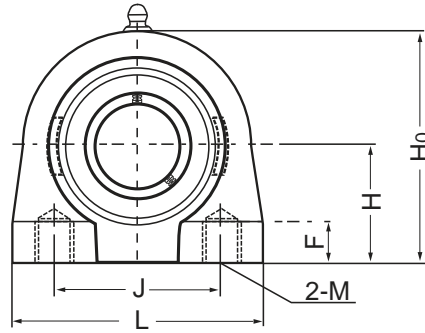

Also available with eccentric locking collar bearing

Unit No.	Shaft Dia. (inch / mm)	Dimensions (inch / mm)									Bearing No.	Housing No.	Mass		
		d	H	L	J	A	H0	B	S	F			M	kg	lbs
SSUCPA 201A 201-8A 202A 202-10A 203A 204-12A 204A	12 mm 1/2 15 mm 5/8 17 mm 3/4 20 mm	1-5/16 33.3	2-3/4 69.9	2 50.8	1-1/2 38.0	2-9/16 65.0	1-7/32 31.0	23/32 18.5	1/2 12.5		3/8-16 NC	SUC 201 201-8 202 202-10 203 204-12 204	SPA 204A	0.8	1.8
SSUCPA 205-14A 205-15A 205A 205-16A	7/8 15/16 25 mm 1	1-7/16 36.5	3 76.2	2 50.8	1-1/2 38.0	2-13/16 71.5	1-3/8 35.0	13/16 20.5	1/2 12.5		3/8-16 NC	SUC 205-14 205-15 205 205-16	SPA 205A	0.9	2.0
SSUCPA 206-18A 206A 206-19A 206-20A	1-1/8 30 mm 1-3/16 1-1/4	1-11/16 42.9	4 101.5	3 76.2	1-1/2 38.0	3-13/32 86.5	1-1/2 38.0	7/8 22.0	5/8 16.0		7/16-14 NC	SUC 206-18 206 206-19 206-20	SPA 206A	1.4	2.5
SSUCPA 207-20A 207-21A 207-22A 207A 207-23A	1-1/4 1-5/16 1-3/8 35 mm 1-7/16	1-7/8 47.6	4-1/4 108.0	3-1/4 82.6	1-7/8 47.5	3-3/4 95.5	1-11/16 43.0	1 25.5	3/4 19.0		1/2-13 NC	SUC 207-20 207-21 207-22 207 207-23	SPA 207A	1.6	3.4
SSUCPA 208-24A 208-25A 208A	1-1/2 1-9/16 40 mm	1-15/16 49.2	4-5/8 117.5	3-1/2 88.9	1-7/8 47.5	3-15/16 100.0	1-15/16 49.0	1-3/16 30.0	3/4 19.0		1/2-13 NC	SUC 208-24 208-25 208	SPA 208A	2	4.4
SSUCPA 209-26A 209-27A 209-28A 209A	1-5/8 1-11/16 1-3/4 45 mm	2-1/8 54.0	5 127	3-3/4 95.3	2 51.0	4-1/4 108.0	1-15/16 49.0	1-3/16 30.0	3/4 19.0		1/2-13 NC	SUC 209-26 209-27 209-28 209	SPA 209A	2.6	5.7
SSUCPA 210-30A 210-31A 210A 210-32A	1-7/8 1-15/16 50 mm 2	2-1/4 57.2	5-3/16 132.0	4 101.6	2 51.0	4-17/32 117.5	2-1/32 51.5	1-9/32 32.5	7/8 22.0		5/8-11 NC	SUC 210-30 210-31 210 210-32	SPA 210A	2.3	5.1

Other sizes could be available upon request. Minimum quantity may apply.
Please refer to page 52 for setscrew maximum torque informations.

Flange Bracket Units

Stainless Steel - SSUCFB Series

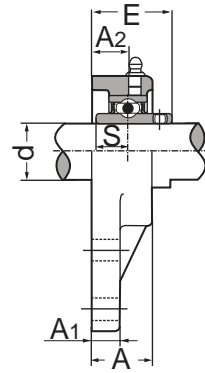
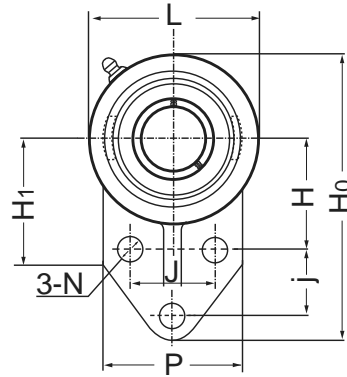

Also available with eccentric locking collar bearing

Unit No.	Shaft Dia. (inch / mm)	Dimensions (inch / mm)													Bolt Size	Bearing No.	Housing No.	Mass	
		d	H0	H1	L	P	H	j	J	A	A1	A2	N	E				S	kg
SSUCFB 201 201-8 202 202-10 203 204 204-12	12 mm 1/2 15 mm 5/8 17 mm 20 mm 3/4	4-1/4 107.9	2-1/16 52	2-1/2 63.5	2-1/2 63.5	1-21/32 42	7/8 22.2	1-1/2 38.1	1 25.4	5/16 8.0	5/8 15.9	13/32 10.0	1.3425 34.1	0.500 12.7	5/16 M8	SUC 201 201-8 202 202-10 203 204-12 204	SFB 204	0.70	1.54
SSUCFB 205-14 205-15 205 205-16	7/8 15/16 25 mm 1	4-3/4 120.7	2-1/16 52	2-3/4 69.9	2-1/2 63.5	1-49/64 45.0	1-1/8 28.6	1-5/8 41.3	1-1/8 28.6	3/8 9.6	21/32 16.7	13/32 10.0	1.4370 36.5	0.5629 14.3	5/16 M8	SUC 205-14 205-15 205 205-16	SFB 205	0.80	1.76
SSUCFB 206-18 206 206-19 206-20	1-1/8 30 mm 1-3/16 1-1/4	5-3/8 136.5	2-5/32 55	3-1/4 82.6	2-3/4 69.9	1-31/32 52.4	1-1/4 31.8	1-7/8 47.6	1-1/4 31.8	3/8 9.6	47/64 18.7	13/32 10.0	1.6102 40.9	0.6259 15.9	5/16 M8	SUC 206-18 206 206-19 206-20	SFB 206	1.00	2.20
SSUCFB 207-20 207-21 207-22 207 207-23	1-1/4 1-5/16 1-3/8 35 mm 1-7/16	6-1/8 155.6	2-7/16 62	3-3/4 95.3	3-1/4 82.6	2-3/8 60.3	1-1/4 31.8	2 50.8	1-7/16 36.5	1/2 12.7	13/16 21.0	33/64 13.1	1.8267 46.4	0.6889 17.5	5/16 M8	SUC 207-20 207-21 207-22 207 207-23	SFB 207	1.60	3.54
SSUCFB 208 208-24 208-25	40 mm 1-1/2 1-9/16	6-15/32 164.3	2-27/32 72	3-15/16 100	3-1/16 77.8	2-23/64 60.0	1-5/8 41.3	1-31/32 50.0	1-31/32 35.7	5/8 15.9	13/16 21.0	15/32 12	2.0157 51.2	0.7480 19.0	3/8 M10	SUC 208 208-24 208-25	SFB 208	1.78	3.92
SSUCFB 209 209-26 209-27 209-28	45 mm 1-5/8 1-11/16 1-3/4	6-27/32 173.9	3 76	4-7/32 107.4	3-5/32 80.2	2-9/16 65	1-11/16 42.9	2-1/8 53.9	1-1/2 38.1	23/32 18.3	55/64 21.8	7/16 11.9	2.0157 51.2	0.7480 19	3/8 M10	SUC 209 209-26 209-27 209-28	SFB 209	2.20	4.84
SSUCFB 210 210-30 210-31 210-32	50 mm 1-7/8 1-15/16 2	7-1/2 190.5	3-7/32 82	4-5/8 117.5	4 101.6	2-15/16 74.6	1-5/8 41.3	2-3/4 69.9	1-1/2 38.1	23/32 18.3	55/64 21.8	33/64 13.1	2.1102 53.6	0.7480 19	3/8 M10	SUC 210 210-30 210-31 210-32	SFB 210	2.50	5.50

Other sizes could be available upon request. Minimum quantity may apply.
Please refer to page 52 for setscrew maximum torque informations.



Take-Up Unit series

Stainless Steel - SSUCST Series

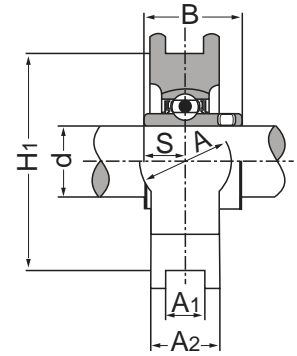
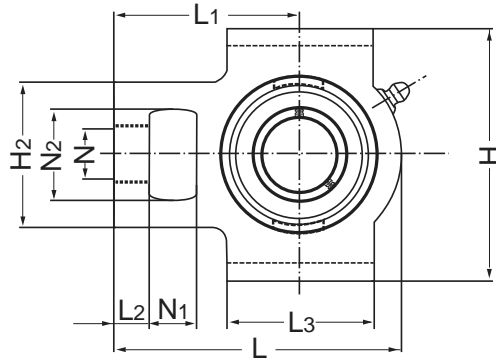

Also available with eccentric locking collar bearing

Unit No.	Shaft Dia. (in / mm)	Dimensions (in / mm)														Bearing No.	Housing No.	Mass	
		d	N1	L2	H2	N2	N	L3	A1	H1	H	L	A	L1	B			S	kg
SSUCST 201 201-8 202 202-10 203 204-12 204	12 mm 1/2 15 mm 5/8 17 mm 3/4 20 mm	5/8 16.0	3/8 9.5	2 51.0	1-1/4 32.0	3/4 19.0	2 51.0	17/32 13.5	3 76.2	3-1/2 88.9	3-11/16 93.5	1-3/8 35.0	2-3/8 60.3	1-7/32 31.0	1/2 12.70	SUC 201 201-8 202 202-10 203 204-12 204	SST 204	1.0	2.1
SSUCST 205-14 205-15 205 205-16	7/8 15/16 25 mm 1	5/8 16.0	3/8 9.5	2 51.0	1-1/4 32.0	3/4 19.0	2 51.0	17/32 13.5	3 76.2	3-1/2 88.9	3-13/16 97.0	1-1/2 38.0	2-7/16 61.9	1-3/8 34.9	9/16 14.29	SUC 205-14 205-15 205 205-16	SST 205	1.2	2.6
SSUCST 206-18 206 206-19 206-20	1-1/8 30 mm 1-3/16 1-1/4	5/8 16.0	3/8 9.5	2-3/16 55.5	1-7/16 36.5	7/8 22.0	2-1/4 57.0	17/32 13.5	3-1/2 88.9	4 101.6	4-7/16 112.5	1-3/4 44.5	2-3/4 69.9	1-1/2 38.1	5/8 15.88	SUC 206-18 206 206-19 206-20	SST 206	1.5	3.4
SSUCST 207-20 207-21 207-22 207 207-23	1-1/4 1-5/16 1-3/8 35 mm 1-7/16	5/8 16.0	1/2 12.5	2-1/2 63.5	1-7/16 36.5	7/8 22.0	2-1/2 57.0	17/32 13.5	3-1/2 88.9	4 101.6	5-1/16 128.5	1-3/4 44.5	3-1/16 77.8	1-11/16 42.9	11/16 17.46	SUC 207-20 207-21 207-22 207 207-23	SST 207	1.8	4.0
SSUCST 208-24 208-25 208	1-1/2 1-9/16 40 mm	3/4 19.0	5/8 16.0	3-1/4 82.5	1-15/16 49.0	1-1/8 28.5	3-1/4 82.5	11/16 17.5	4 101.6	4-1/2 114.3	5-11/16 144.5	2-1/8 54.0	3-1/2 88.9	1-15/16 49.2	3/4 19.05	SUC 208-24 208-25 208	SST 208	2.7	6.0
SSUCST 209-26 209-27 209-28 209	1-5/8 1-11/16 1-3/4 45 mm	3/4 19.0	5/8 16.0	3-1/4 82.5	1-15/16 49.0	1-1/8 28.5	3-1/4 82.5	11/16 17.5	4 101.6	4-5/8 117.5	5-11/16 144.5	2-3/16 55.5	3-7/16 87.3	1-15/16 49.2	3/4 19.05	SUC 209-26 209-27 209-28 209	SST 209	2.7	6.0
SSUCST 210-30 210-31 210 210-32	1-7/8 1-15/16 50 mm 2	3/4 19.0	5/8 16.0	3-1/4 82.5	1-15/16 49.0	1-1/8 28.5	3-3/8 85.5	11/16 17.5	4 101.6	4-5/8 117.5	5-7/8 149.0	2-3/16 55.5	3-9/16 90.5	2-1/32 51.6	3/4 19.05	SUC 210-30 210-31 210 210-32	SST 210	2.7	6.0

Other sizes could be available upon request. Minimum quantity may apply.
Please refer to page 52 for setscrew maximum torque informations.

Hanger Units

Stainless Steel - SSUCHA Series

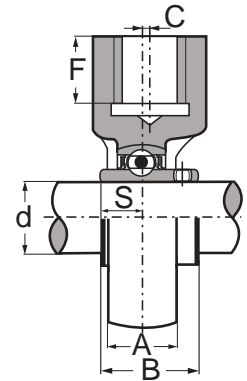
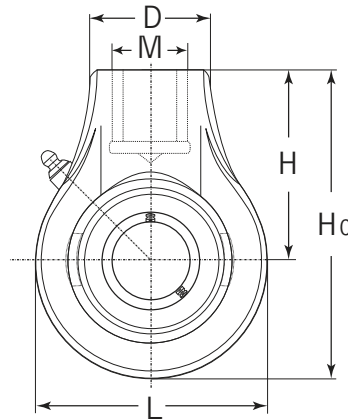

Also available with eccentric locking collar bearing

Unit No.	Shaft Dia. (inch / mm)	Dimensions (inch / mm)										Bearing No.	Housing No.	Mass	
		d	L	H0	C	A	H	M	D	F	B			S	kg
SSUCHA 201 201-8 202 202-10 203 204-12 204	12 mm 1/2 15 mm 5/8 17 mm 3/4 20 mm	2-17/32 64	3-25/32 96	0 0	13/16 21	2-33/64 64	Rp 3/4	1-9/16 40	3/4 19	1.2205 31.0	0.500 12.7	SUC 201 201-8 202 202-10 203 204-12 204	SHA 204	0.7	1.5
SSUCHA 205-14 205-15 205 205-16	7/8 15/16 25 mm 1	3-1/16 78	4-1/16 103	0 0	15/16 24	2-33/64 64	Rp 3/4	1-9/16 40	3/4 19	1.3425 34.1	0.563 14.3	SUC 205-14 205-15 205 205-16	SHA 205	1.0	2.2
SSUCHA 206-18 206 206-19 206-20	1-1/8 30 mm 1-3/16 1-1/4	3-1/16 78	4-1/16 103	0 0	1-3/32 28	2-33/64 64	Rp 3/4	1-9/16 40	3/4 19	1.5000 38.1	0.626 15.9	SUC 206-18 206 206-19 206-20	SHA 206	1.0	2.2
SSUCHA 207-20 207-21 207-22 207 207-23	1-1/4 1-5/16 1-3/8 35 mm 1-7/16	3-5/8 92	4-9/16 116	0 0	1-3/16 30	2-3/4 70	Rp 3/4	1-9/16 40	3/4 19	1.6890 42.9	0.689 17.5	SUC 207-20 207-21 207-22 207 207-23	SHA 207	1.4	3.1
SSUCHA 208-24 208-25 208	1-1/2 1-9/16 40 mm	3-25/32 96	4-3/4 121	3/32 2	1-5/16 33	2-7/8 73	Rp 3/4	1-9/16 40	3/4 19	1.9370 49.2	0.748 19.0	SUC 208-24 208-25 208	SHA 208	1.5	3.3
SSUCHA 209-26 209-27 209-28 209	1-5/8 1-11/16 1-3/4 45 mm	4-1/4 108	5-11/32 136	3/16 5	1-3/8 35	3-15/64 82	Rp 1	1-7/8 40	13/16 21	1.9370 49.2	0.748 19.0	SUC 209-26 209-27 209-28 209	SHA 209	2.1	4.6
SSUCHA 210-30 210-31 210 210-32	1-7/8 1-15/16 50 mm 2	4-21/32 118	5-19/32 142	3/16 5	1-15/32 37	3-17/64 83	Rp 1	1-7/8 40	13/16 21	2.0315 51.6	0.748 19.0	SUC 210-30 210-31 210 210-32	SHA 210	2.6	5.7

Other sizes could be available upon request. Minimum quantity may apply. Please refer to page 52 for setscrew maximum torque informations.

Designation of Thread	Dimensions (mm)		
	Major Diameter of Internal Thread	Pitch Diameter	Minor Diameter of Internal Thread
Rp 3/4 (PS 3/4)	26.441	25.279	24.117
Rp 1 (PS1)	33.249	31.770	30.291



Pressed Stainless Steel

Housing Pillow Block - SSBSP Series

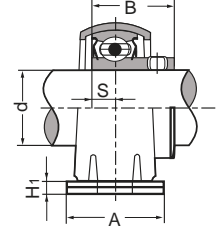
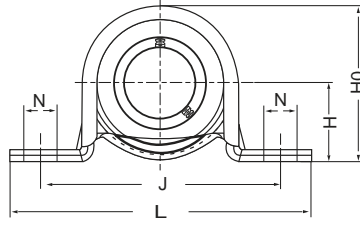

Unit No.	Shaft Dia. (inch / mm)	Dimensions (inch / mm)									Bolt Size	Bearing No.	Housing No.	Mass	
		d	H	L	J	A	N	H1	H0	B				S	kg
SSBSPP 201 201-8 202 202-10 203	12 mm 1/2 15 mm 5/8 17 mm	7/8 22.2	3-3/8 86	2-11/16 68.3	31/32 25	3/8 9.5	0.126 3.2	1-23/32 43.8	0.8661 22	0.236 6	5/16 M8	SSB 201 201-8 202 202-10 203	SPP 203	0.2	0.2
SSBSPP 204-12 204	3/4 20 mm	1 25.4	3-27/32 98	3 76.2	1-1/4 32	3/8 9.5	0.126 3.2	2 50.5	0.9843 25	0.276 7	5/16 M8	SSB 204-12 204	SPP 204	0.4	0.2
SSBSPP 205-14 205-15 205 205-16	7/8 15/16 25 mm 1	1-1/8 28.6	4-1/4 108	3-3/8 85.7	1-1/4 32	7/16 11.5	0.157 4.0	2-7/32 56.6	1.0630 27	0.295 7.5	3/8 M10	SSB 205-14 205-15 205 205-16	SPP 205	0.7	0.3

Other sizes could be available upon request. Minimum quantity may apply.
Please refer to page 52 for setscrew maximum torque informations.

Housing Round Flange Units - SSBSPF Series

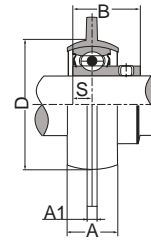
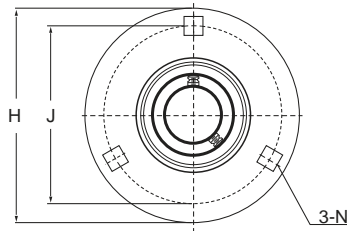

Unit No.	Shaft Dia. (inch / mm)	Dimensions (inch / mm)								Bolt Size	Bearing No.	Housing No.	Mass	
		d	H	J	A1	N	A	B	S				D min.	kg
SSBSPF 201 201-8 202 202-10 203	12 mm 1/2 15 mm 5/8 17 mm	3-3/16 81.0	2-1/2 63.5	0.157 4	9/32 7.1	9/16 14	0.8661 22.0	0.236 6	1-59/64 49	1/4 M6	SSB 201 20-8 202 202-10 203	PP 203 SS	0.2	0.4
SSBSPF 204-12 204	3/4 20 mm	3-35/64 90.1	2-13/16 71.4	0.157 4	23/64 9	5/8 16	0.9843 25.0	0.276 7	2-13/64 56	5/16 M8	SSB 204-12 204	PP 204 SS	0.3	0.7
SSBSPF 205-14 205-15 205 205-16	7/8 15/16 25 mm 1	3-3/4 95.3	3 76.2	0.157 4	23/64 9	23/32 18	1.0630 27.0	0.295 7.5	2-23/64 60	5/16 M8	SSB 205-14 205-15 205 205-16	PP 205 SS	0.3	0.7

Other sizes could be available upon request. Minimum quantity may apply.
Please refer to page 52 for setscrew maximum torque informations.



Housing Flange Units - SSBSPFT Series

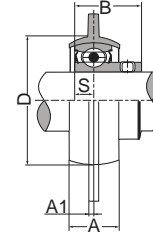
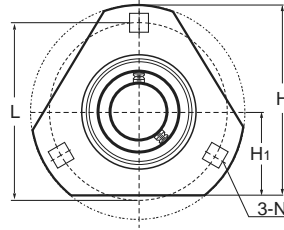
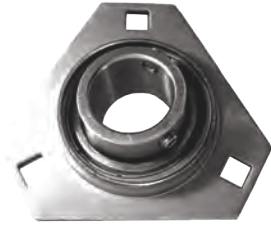

Unit No.	Shaft Dia. (inch / mm)	Dimensions (inch / mm)									Bolt Size	Bearing No.	Housing No.	Mass	
		d	H	L	A1	A	N	H1	B	S				D min.	kg
SSBSPFT 201 201-8 202 202-10 203	12 mm 1/2 15 mm 5/8 17 mm	2-23/32 69.1	2-1/2 63.5	0.079 2.0	9/16 14.3	9/32 7.1	1-1/8 28.6	0.866 22.0	0.236 6.0	1-15/16 49.2	1/4 M6	SSB 201 20-8 202 202-10 203	PFT 203 SS	2.2	0.5
SSBSPFT 204-12 204	3/4 20 mm	3 76.2	2-13/16 71.4	0.079 2.0	5/8 16.0	11/32 9.0	1-5/16 33.3	0.9842 25	0.276 7.0	2-3/16 56.0	5/16 M8	SSB 204-12 204	PFT 204 SS	2.2	0.5
SSBSPFT 205-14 205-15 205 205-16	7/8 15/16 25 mm 1	3-1/8 79.4	3 76.2	0.079 2.0	11/16 18.0	11/32 9.0	1-3/8 34.9	1.063 27.0	0.295 7.5	2-3/8 60.0	5/16 M8	SSB 205-14 205-15 205 205-16	PFT 205 SS	3.6	0.8

Other sizes could be available upon request. Minimum quantity may apply.
Please refer to page 52 for setscrew maximum torque informations.

Oval Flange Units - SSBSPFL Series

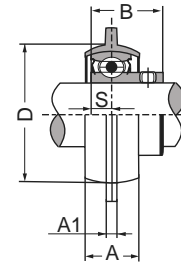
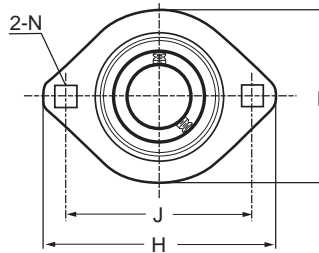
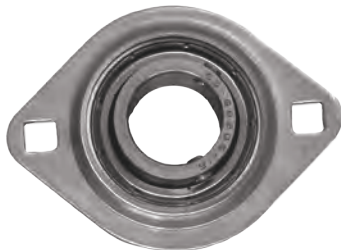

Unit No.	Shaft Dia. (inch / mm)	Dimensions (inch / mm)									Bolt Size	Bearing No.	Housing No.	Mass	
		d	H	J	A1	N	A	L	B	S				D min.	kg
SSBSPFL 201 201-8 202 202-10 203	12 mm 1/2 15 mm 5/8 17 mm	3-3/16 81	2-1/2 63.5	0.157 4	9/32 7.1	9/16 14	2-5/16 59	0.8661 22.0	0.236 6	1-59/64 49	1/4 M6	SSB 201 201-8 202 202-10 203	PFL 203 SS	0.1	0.2
SSBSPFL 204-12 204	3/4 20 mm	3-17/32 90	2-13/16 71.4	0.157 4	23/64 9	5/8 16	2-5/8 67	0.9843 25.0	0.276 7	2-13/64 56	5/16 M8	SSB 204-12 204	PFL 204 SS	0.2	0.4
SSBSPFL 205-14 205-15 205 205-16	7/8 15/16 25 mm 1	3-3/4 95	2-63/64 75.8	0.157 4	23/64 9	23/32 18	2-25/64 71	1.0630 27.0	0.295 7.5	2-23/64 60	5/16 M8	SSB 205-14 205-15 205 205-16	PFL 205 SS	0.3	0.7

Other sizes could be available upon request. Minimum quantity may apply.
Please refer to page 52 for setscrew maximum torque informations.



Ball Bearing Inserts

Stainless Steel - SUC Series

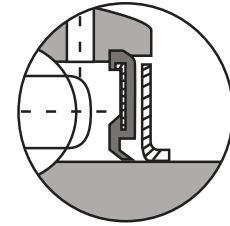
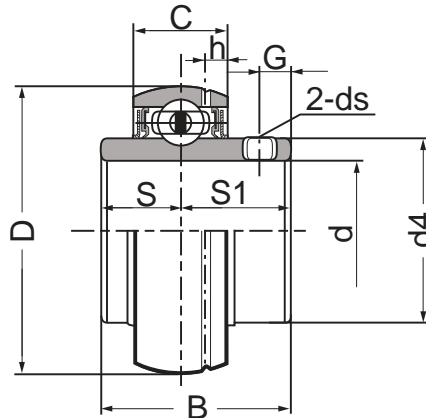
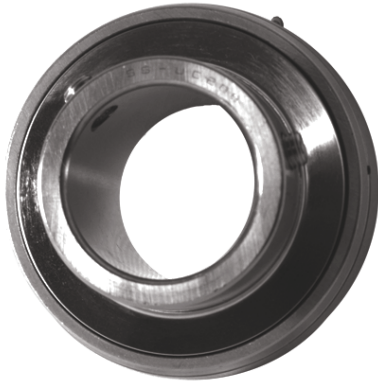

Dual Seal

Unit No.	Shaft Diameter (in / mm)	Dimensions (in / mm)									Basic Load Rating lbf / N		Mass	
	d	D	B	C	S	S1	G	ds	d4	h	Dynamic Cr	Static C0r	kg	lbs
SUC 201	12 mm												0.21	0.46
201-8	1/2												0.21	0.46
202	15 mm	1.8504	1.2205	0.6290	0.500	0.7205	0.197	10-32	1.142	0.185	2524	1320	0.20	0.44
202-10	5/8	47	31.0	17	12.7	18.3	5.0	M5 X 0.8	29.01	4.7	11228	5873	0.19	0.42
203	17 mm												0.18	0.40
204-12	3/4												0.18	0.39
204	20 mm												0.17	0.37
SUC 205-14	7/8	2.0472	1.343	0.6693	0.563	0.7756	0.217	10-32	1.339	0.177	2524	1320	0.23	0.51
205-15	15/16	52	34.1	17	14.3	19.7	5.5	M5 X 0.8	34.01	4.5	11228	5873	0.21	0.46
205	25 mm												0.20	0.44
205-16	1												0.20	0.44
SUC 206-18	1-1/8	2.4409	1.5000	0.7480	0.626	0.8740	0.236	1/4-28	1.594	0.181	3504	1909	0.37	0.82
206	30 mm	62	38.1	19	15.9	22.2	6.0	M6 X 0.75	40.49	4.6	15588	8490	0.33	0.73
206-19	1-3/16												0.33	0.73
206-20	1-1/4												0.30	0.66
SUC 207-20	1-1/4	2.8346	1.6890	0.7874	0.689	1.0000	0.256	1/4-28	1.843	0.181	4624	2595	0.55	1.21
207-21	1-5/16	72	42.9	20	17.5	25.4	6.5	M6 X 0.75	46.81	4.6	20568	11543	0.52	1.15
207-22	1-3/8												0.49	1.08
207	35 mm												0.49	1.08
207-23	1-7/16												0.46	1.01
SUC 208-24	1-1/2	3.1496	1.9370	0.8268	0.748	1.1890	0.315	5/16-24	2.079	0.177	4632	3034	0.69	1.52
208-25	1-9/16	80	49.2	21	19.0	30.2	8.0	M8 X 1	52.81	4.5	20604	13496	0.66	1.46
208	40 mm												0.65	1.43
SUC 209-26	1-5/8	3.3465	1.9370	0.8661	0.748	1.1890	0.315	5/16-24	2.307	0.193	5888	3450	0.80	1.76
209-27	1-11/16	85	49.2	22	19.0	30.2	8.0	M8 X 1	58.60	4.9	26192	15345	0.76	1.68
209-28	1-3/4												0.71	1.57
209	45 mm												0.70	1.54
SUC 210-30	1-7/8	3.5433	2.0315	0.9055	0.748	1.2835	0.354	5/16-24	2.449	0.232	6320	3885	0.87	1.92
210-31	1-15/16	90	51.6	23	19.0	32.6	9.0	M8 X 1	62.20	5.9	28112	17280	0.82	1.81
210	50 mm												0.80	1.76
210-32	2												0.77	1.69
SUC 211-32	2	3.9370	2.1890	0.9440	0.874	1.3150	0.354	3/8-24	2.756	0.236	7808	4914	1.23	2.71
211-34	2-1/8	100	55.6	24	22.2	33.4	9.0	M8 X 1	70.00	6.0	34732	21859	1.18	2.60
211	55 mm												1.08	2.376
211-35	2-3/16												1.06	2.34
SUC 212-36	2-1/4	4.3307	2.5630	1.024	1.000	1.5630	0.394	3/8-24	3.031	0.244	9440	6071	1.66	3.66
212	60 mm	110	65.1	26	25.4	39.7	10.0	M10 X 1.25	76.99	6.2	41992	27008	1.53	3.37
212-38	2-3/8												1.51	3.33
212-39	2-7/16												1.44	3.17

Other sizes could be available upon request. Minimum quantity may apply.
Please refer to page 52 for setscrew maximum torque informations.

Ball Bearing Inserts

Stainless Steel - SHC Eccentric Collar Series

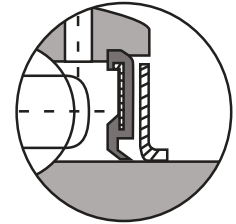
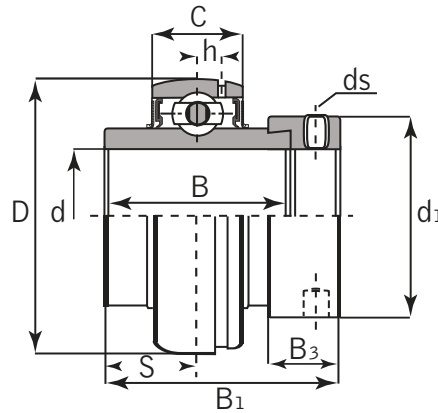

Dual Seal

Unit No.	Shaft Dia. (inch / mm)	Dimensions (inch / mm)									Basic Load Rating lbf / N		Mass	
		d	D	d1	B	B1	B3	C	S	h	ds	Dynamic	Static	kg
SHC 204 204-12	20 mm 3/4	1.8504 47	1.311 33.3	1.3465 34.2	1.7205 43.7	0.5315 13.5	0.6693 17	0.6793 17.1	0.146 3.7	1/4-28 UNF M6 x 0.75	2886 12840	1495 6650	0.23 0.23	0.51 0.51
SHC 205 205-14 205-15 205-16	25 mm 7/8 15/16 1	2.0472 52	1.5000 38.1	1.3740 34.9	1.7480 44.4	0.5315 13.5	0.6693 17	0.6890 17.5	0.154 3.9	1/4-28 UNF M6 x 0.75	3152 14020	1771 7880	0.27 0.31 0.29 0.27	0.59 0.68 0.64 0.59
SHC 206 206-17 206-18 206-19 206-20	30 mm 1-1/16 1-1/8 1-3/16 1-1/4	2.4409 62	1.7520 44.5	1.4370 36.5	1.9055 48.4	0.6260 15.9	0.7480 19	0.7205 18.3	0.197 5.0	5/16-24 UNF M8 x 1	4375 19460	2542 11310	0.45 0.50 0.47 0.45 0.42	0.99 1.10 1.03 0.99 0.92
SHC 207 207-20 207-21 207-22 207-23	35 mm 1-1/4 1-5/16 1-3/8 1-7/16	2.8346 72	2.189 55.6	1.4803 37.6	2.0118 51.1	0.6890 17.5	0.7874 20	0.7402 18.8	0.224 5.7	5/16-24 UNF M8 x 1	5771 25670	3439 15300	0.60 0.67 0.63 0.60 0.57	1.32 1.47 1.39 1.32 1.25
SHC 208 208-24 208-25	40 mm 1-1/2 1-9/16	3.1496 80	2.3740 60.3	1.6850 42.8	2.2165 56.3	0.7205 18.3	0.8270 21	0.8425 21.4	0.244 6.2	5/16-24 UNF M8 x 1	6636 29520	4078 18140	0.79 0.84 0.80	1.74 1.85 1.76
SHC 209 209-26 209-27 209-28	45 mm 1-5/8 1-11/16 1-3/4	3.3465 85	2.5000 63.5	1.6850 42.8	2.2165 56.3	0.7205 18.3	0.8661 22	0.8425 21.4	0.252 6.4	5/16-24 UNF M8 x 1	7119 31670	4649 20680	0.85 0.96 0.91 0.87	1.87 2.11 2.00 1.91
SHC 210 210-30 210-31 210-32	50 mm 1-7/8 1-15/16 2	3.5433 90	2.7520 69.9	1.9370 49.2	2.4685 62.7	0.7204 18.3	0.9449 24	0.9685 24.6	0.256 6.5	5/16-24 UNF M8x 1	7884 35070	5211 23180	0.99 1.08 1.02 0.96	2.18 2.38 2.24 2.11
SHC 211 211-32 211-34 211-35	55 mm 2 2-1/8 2-3/16	3.9370 100	3.000 76.2	2.1850 55.5	2.8110 71.4	0.8150 20.7	0.9843 25	1.0945 27.8	0.276 7.0	3/8-24 UNF M10 x 1.25	9752 43380	6569 29220	1.32 1.52 1.37 1.29	2.90 3.34 3.01 2.84
SHC 212 212-36 212-38 212-39	60 mm 2-1/4 2-3/8 2-7/16	4.3307 110	3.3150 84.2	2.4370 61.9	3.0630 77.8	0.8780 22.3	1.0630 27	1.2205 31	0.299 7.6	3/8-24 UNF M10 x 1.25	10736 47760	7403 32930	1.88 2.04 1.90 1.77	4.14 4.49 4.18 3.89

Other sizes could be available upon request. Minimum quantity may apply.
Please refer to page 52 for setscrew maximum torque informations.



Ball Bearing Inserts

Stainless Steel - SSER Series

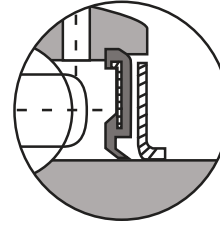
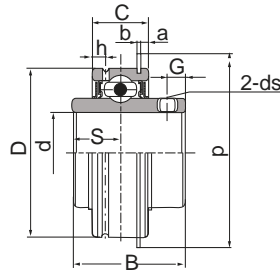

Dual Seal

Unit No.	Shaft Dia. (inch / mm)	Dimensions (inch / mm)										Basic Load Rating lbf / N		Mass		
		d	D	B	C	S	a	b	p	G	h	ds	Dynamic Cr	Static C0r	kg	lbs
SSER 201-8	1/2														0.26	0.57
202	15 mm														0.25	0.55
202-10	5/8	1.8504	1.219	0.626	0.406	0.094	0.042	2.067	0.177	0.150	1/4-28	2524	1320	0.24	0.53	
203	17 mm	47	31.0	15.9	10.3	2.3	1.1	52.5	4.5	3.8	M6 X 1	11228	5873	0.23	0.51	
204-12	3/4													0.22	0.49	
204	20 mm													0.21	0.46	
SSER 205-14	7/8													0.31	0.68	
205-15	15/16	2.0472	1.375	0.750	0.515	0.094	0.042	2.272	0.197	0.203	1/4-28	2524	1320	0.30	0.66	
205	25 mm	52	34.9	19	13.1	2.3	1.1	57.7	5	5.1	M6 X 1	11228	5873	0.29	0.64	
205-16	1													0.28	0.62	
SSER 206-18	1-1/8													0.40	0.88	
206	30 mm	2.4409	1.500	0.875	0.625	0.125	0.065	2.658	0.197	0.219	1/4-28	3504	1909	0.39	0.86	
206-19	1-3/16	62	38.1	22.2	15.8	3.2	1.6	67.5	5	5.6	M6 X 1	15588	8490	0.38	0.84	
206-20	1-1/4													0.36	0.79	
SSER 207-20	1-1/4													0.62	1.37	
207-21	1-5/16	2.8346	1.688	0.937	0.688	0.125	0.065	3.078	0.236	0.219	5/16-24	4624	2595	0.59	1.30	
207-22	1-3/8	72	42.8	23.8	17.5	3.2	1.6	78.2	6	5.6	M8 X 1	20568	11528	0.56	1.23	
207	35 mm													0.55	1.21	
207-23	1-7/16													0.53	1.17	
SSER 208-24	1-1/2													0.91	2.01	
208-25	1-9/16	3.1496	1.937	1.093	0.750	0.125	0.065	3.406	0.315	0.250	5/16-24	4632	3034	0.88	1.94	
208	40 mm	80	49.2	27.8	19	3.2	1.6	86.5	8	6.4	M8 X 1	20604	13493	0.86	1.89	

Ball Bearing Inserts

Stainless Steel - SSB & SSA Series



SSB

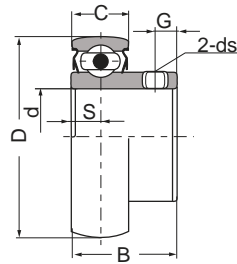

SSB



SSA

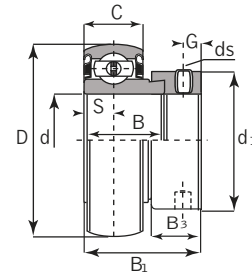

SSA

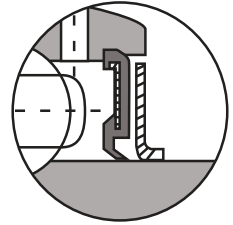

Dual Seal

Unit No.	Shaft Dia. (inch / mm)	Dimensions (inch / mm)						Basic Load Rating lbf / N		Mass	
	d	D	B	C	S	G	ds	Dynamic Cr	Static C0r	kg	lbs
SSB 201 201-8 202 202-10 203	12 mm 1/2 15 mm 5/8 17 mm	1.5748 40	0.866 22	0.472 12	0.236 6	0.177 4.5	1/4-28 M6 X 1	2304 10248	1113 4950	0.10 0.09 0.08 0.08 0.08	0.22 0.20 0.18 0.18 0.18
SSB 204 204-12	20 mm 3/4	1.8504 47	0.984 25	0.551 14	0.275 7	0.177 4.5	1/4-28 M6 X 1	2304 10248	1113 4950	0.13 0.12	0.29 0.26
SSB 205 205-14 205-15 205-16	25 mm 1-1/8 15/16 1	2.0472 52	1.062 27	0.591 15	0.295 7.5	0.217 5.5	1/4-28 M6 X 1	2522 11216	1324 5888	0.18 0.17 0.17 0.16	0.40 0.37 0.37 0.35
SSB 206 206-18 206-19 206-20	30 mm 1-1/8 1-3/16 1-1/4	2.4409 62	1.181 30	0.630 16	0.315 8	0.217 5.5	1/4-28 M6 X 1	4375 19460	2542 11306	0.25 0.26 0.25 0.23	0.55 0.57 0.55 0.51
SSB 207 207-20 207-21 207-22 207-23	35 mm 1-1/4 1-5/16 1-3/8 1-7/16	2.8346 72	1.2598 32	0.6693 17	0.3346 8.5	0.2362 6	5/16-24 M8 X 1	57706 25670	34394 15.30	0.37 0.41 0.39 0.37 0.35	0.81 0.90 0.86 0.81 0.77
SSB 208 208-24 208-25	40 mm 1-1/2 1-9/16	3.1496 80	1.3386 34	0.7087 18	0.3543 9	0.3150 8	5/16-24 M8 X 1	6636 29520	4078 18140	0.45 0.48 0.45	0.99 1.06 0.99

Other sizes could be available upon request. Minimum quantity may apply. Please refer to page 52 for setscrew maximum torque informations.

Unit No.	Shaft Dia. (inch / mm)	Dimensions (inch / mm)									Basic Load Rating lbf / N		Weight	
	d	D	d1	B	B1	B3	C	S	G	ds	Dynamic Cr	Static C0r	kg	lbs
SSA 201 201-8 202 202-10 203	12 mm 1/2 15 mm 5/8 17 mm	1.5748 40	1.126 28.6	0.7520 19.1	1.126 28.6	0.5315 13.5	0.4724 12	0.2362 6	0.1969 5	1/4-28 UNF M6 x 0.75	2151 9570	1057 4700	0.12 0.14 0.11 0.13 0.10	0.26 0.31 0.24 0.29 0.22
SSA 204 204-12	20 mm 3/4	1.8504 47	1.311 33.3	0.8465 21.5	1.2205 31	0.5315 13.5	0.5512 14	0.2755 7	0.1969 5	1/4-28 UNF M6 x 0.75	2886 12840	1495 6650	0.16 0.15	0.35 0.33
SSA 205 205-14 205-15 205-16	25 mm 7/8 15/16 1	2.0472 52	1.500 38.1	0.8465 21.5	1.2205 31	0.5315 13.5	0.5905 15	0.2953 7.5	0.1969 5	1/4-28 UNF M6 x 0.75	3152 14020	1771 7880	0.21 0.19 0.18 0.18	0.46 0.42 0.40 0.40
SSA 206 206-18 206-19 206-20	30 mm 1-1/8 1-3/16 1-1/4	2.4409 62	1.752 44.5	0.9370 23.8	1.4055 35.7	0.6260 15.9	0.6299 16	0.3150 8	0.2362 6	5/16-24 UNF M8 x 1	4375 19460	2542 11310	0.30 0.30 0.30 0.29	0.66 0.66 0.66 0.64
SSA 207 207-20 207-21 207-22 207-23	35 mm 1-1/4 1-5/16 1-3/8 1-7/16	2.8346 72	2.1890 55.6	1 25.4	1.5315 38.9	0.6890 17.5	0.6693 17	0.3346 8.5	0.2559 6.5	5/16-24 M8 x 1	5771 25670	3439 15300	0.50 0.55 0.53 0.50 0.47	1.102 1.213 1.168 1.036
SSA 208 208-24 208-25	40 mm 1-1/2 1-9/16	3.1496 80	2.3740 60.3	1.1890 30.2	1.7205 43.7	0.7205 18.3	0.7087 18	0.3543 9	0.2559 6.5	5/16-24 M8 x 1	29520 6636	18140 4078	0.63 0.67 0.65	1.389 1.477 1.433



Thermoplastic Series

SUCTP200 Series

SUCTF200 Series

SUCTFL200 Series

Thermoplastic housings are designed to meet particular engineering demands in the food, beverage, pharmaceutical, chemical and photo industries. They are mainly used to meet critical demands such as frequent wash downs, corrosion resistance, exposure to harsh chemicals and resistance to contaminants.

Their main features are:

- High quality reinforced PBT polymer
- Excellent low water absorption as compared to nylon
- Exceptional dimension stability due to low water absorption
- Non-magnetic

GRB currently stocks TP Pillow Blocks and TF and TFL Flanges; however, other housing styles are available upon request.

In addition, GRB offers back seals and open covers upon request. *Minimum quantities may apply.*

Plastic Covers: Open/Close Type

Shaft Diameter		Dimensions (mm)					
mm	inch	K	N	L	M	D	b
12	1/2	32	7	23	50	52	6
15	9/16 · 5/8	32	7	23	50	52	6
17	11/16	32	7	23	50	52	6
20	3/4	32	7	23	50	52	6
25	13/16 · 7/8 · 15/16 · 1	37	7	25	55	62	6
30	1-1/16 · 1-1/8 · 1-3/16 · 1-1/4	42	7	30	64	72	6
35	1-1/4 · 1-5/16 · 1-3/8 · 1-7/16	47	7	32	74.5	82	6
40	1-1/2 · 1-9/16	52	7	37	84	88	6
45	1-5/8 · 1-11/16 · 1-3/4	57	7	41	89	93	6
50	1-13/16 · 1-7/8 · 1-15/16 · 2	62	7	47	94	98	6
55	2-1/8 · 2-3/16 · 2	67	7	49	102	108	6
60	2-1/4 · 2-3/8 · 2-7/16	72	7	48	116	116	6

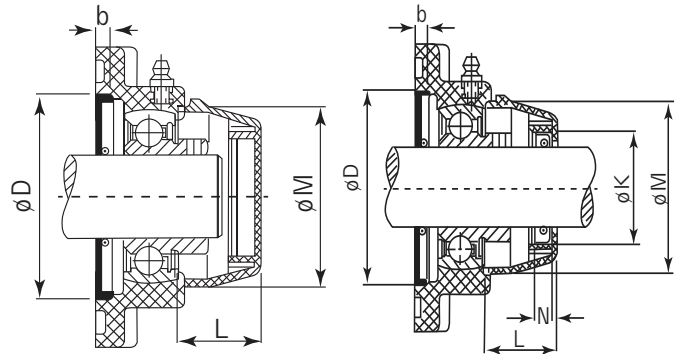

Flange Units

Back Seals

Size	Dimensions for PTA Housings			Dimensions for F FL FB Housing		
	d	b	D	d	b	D
BS204	20	3	52	20	6	52
BS205	25	3	56	25	6	62
BS206	30	3	66	30	6	72
BS207	35	3	76	35	6	82
BS208	40	3	86	40	6	88
BS209	45	3	90	45	6	93
BS210	50	3	96	50	6	98
BS211	55	3	107	55	6	108
BS212	60	3	116	60	6	116

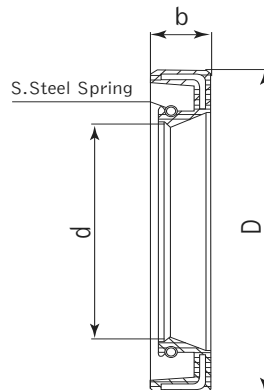

Thermoplastic SUCTP 200 Series

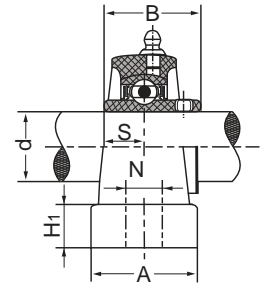
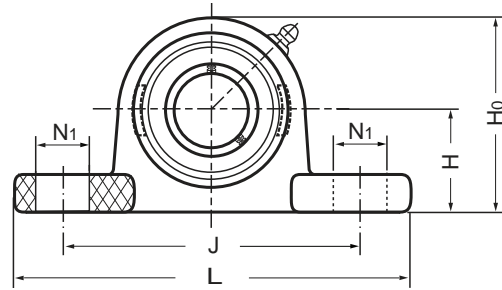
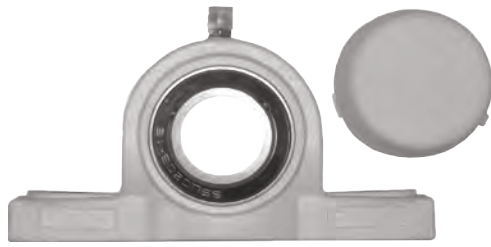

Unit No.	Shaft Diameter (inch / mm)	Dimensions (inch / mm)										Bolt Size (inch / mm)	Bearing No.	Housing No.	Mass	
		d	H	L	J	A	N	N1	H1	H0	B				S	kg
SUCTP 201 201-8 202 202-10 203 204-12 204	12 mm 1/2 15 mm 5/8 17 mm 3/4 20 mm	1-5/16 33.3	5 127	3-3/4 95.3	1-1/2 38	7/16 11	9/16 14	9/16 14.2	2-37/64 65.5	1.22 31.0	1/2 12.7	3/8 M10	SUC 201 201-8 202 202-10 203 204-12 204	TP 204	0.29	0.63
SUCTP 205-14 205-15 205 205-16	7/8 15/16 25 mm 1	1-7/16 36.5	5-1/2 140	4-1/8 105	1-1/2 38	7/16 11	9/16 14	37/64 14.5	2-51/64 71	1-11/32 34.1	9/16 14.3	3/8 M10	SUC 205-14 205-15 205 205-16	TP 205	0.34	0.74
SUCTP 206-18 206 206-19 206-20	1-1/8 30 mm 1-3/16 1-1/4	1-11/16 42.9	6-3/8 162	4-11/16 119	1-13/16 46	9/16 14	45/64 18	45/64 17.8	3-19/64 84	1-1/2 38.1	5/8 15.9	1/2 M12	SUC 206-18 206 206-19 206-20	TP 206	0.54	1.18
SUCTP 207-20 207-21 207-22 207 207-23	1-1/4 1-5/16 1-3/8 35 mm 1-7/16	1-7/8 47.6	6-39/64 168	5 127	1-57/64 48	9/16 14	45/64 18	45/64 18	3-23/32 94.5	1-11/16 42.9	11/16 17.5	1/2 M12	SUC 207-20 207-21 207-22 207 207-23	TP 207	0.78	1.71
SUCTP 208-24 208-25 208	1-1/2 1-9/16 40 mm	1-15/16 49.2	7-1/4 184	5-25/64 137	2-1/8 54	9/16 14	49/64 19.8	49/64 19.5	3-57/64 99	1-15/16 49.2	3/4 19	1/2 M12	SUC 208-24 208-25 208	TP 208	0.97	2.14
SUCTP 209-26 209-27 209-28 209	1-5/8 1-11/16 1-3/4 45 mm	2-1/8 54	7-9/16 192	5-3/4 146	2-1/8 54	11/16 17	25/32 20	29/32 23	4-11/64 106	1-15/16 49.2	3/4 19	5/8 M16	SUC 209-26 209-27 209-28 209	TP 209	1.09	2.33
SUCTP 210-30 210-31 210 210-32	1-7/8 1-15/16 50 mm 2	2-1/4 57.2	8-1/8 206	6-1/4 159	2-23/64 60	11/16 17	25/32 20	29/32 23	4-31/64 114	2-1/32 51.6	3/4 19	5/8 M16	SUC 210-30 210-31 210 210-32	TP 210	1.20	2.64



Thermoplastic

SUCTF 200 Series

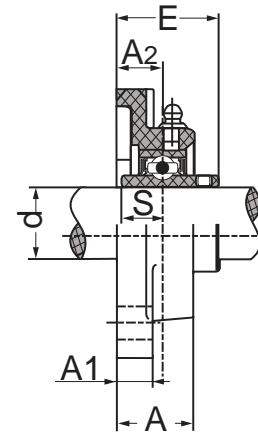
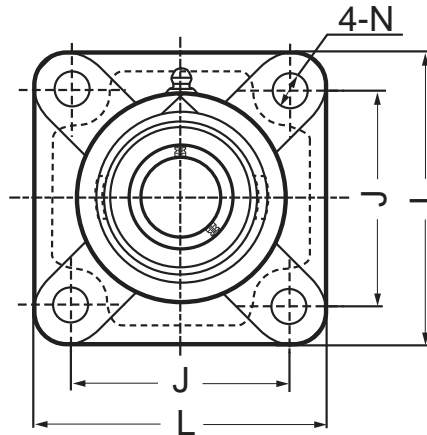
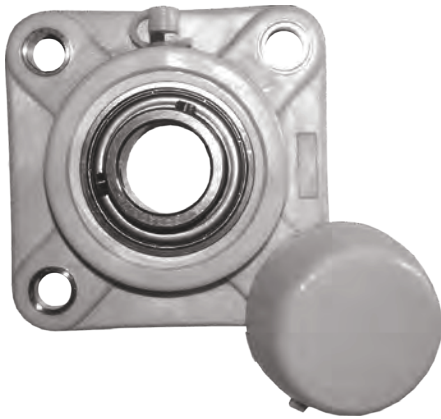

Unit No.	Shaft Diameter (inch / mm)	Dimensions (inch / mm)								Bolt Size	Bearing No.	Housing No.	Mass	
		d	L	J	A1	A	N	E	A2				S	kg
SUCTF 201 201-8 202 202-10 203 204-12 204	12 mm 1/2 15 mm 5/8 17 mm 3/4 20 mm	3-3/8 86	2-1/2 63.5	33/64 13.4	1-3/32 27.8	7/16 11	1-27/64 36.3	45/64 18	1/2 12.7	3/8 M10	SUC 201 201-8 202 202-10 203 204-12 204	TF 204	.29	.71
SUCTF 205-14 205-15 205 205-16	7/8 15/16 25 mm 1	3-3/4 95	2-3/4 70	9/16 14	1-7/64 28	7/16 11	1.29/64 36.7	21/32 17	9/16 14.3	3/8 M10	SUC 205-14 205-15 205 205-16	TF 205	.34	.80
SUCTF 206-18 206 206-19 206-20	1-1/8 30 mm 1-3/16 1-1/4	4-1/4 107	3-1/4 83	9/16 14.3	1-1/4 31.5	7/16 11	1-5/8 41.4	3/4 19.2	5/8 15.9	3/8 M10	SUC 206-18 206 206-19 206-20	TF 206	.54	1.12
SUCTF 207-20 207-21 207-22 207 207-23	1-1/4 1-5/16 1-3/8 35 mm 1-7/16	4-5/8 118	3-5/8 92	39/64 15.5	1-3/8 34.8	33/64 13	1-27/32 46.9	27/32 21.5	11/16 17.5	1/2 M12	SUC 207-20 207-21 207-22 207 207-23	TF 207	.78	1.65
SUCTF 208-24 208-25 208	1-1/2 1-9/16 40 mm	5-1/8 130	4 102	21/32 17	1-15/32 37.5	35/64 14	2-3/32 53.2	29/32 23	3/4 19	1/2 M12	SUC 208-24 208-25 208	TF 208	.97	2.15
SUCTF 209-26 209-27 209-28 209	1-5/8 1-11/16 1-3/4 45 mm	5-3/8 137	4-1/8 105	3/4 19	1-39/64 41	21/32 17	2-43/64 57.6	15/16 24	3/4 19	5/8 M16	SUC 209-26 209-27 209-28 209	TF 209	1.09	2.45
SUCTF 210-30 210-31 210 210-32	1-7/8 1-15/16 50 mm 2	5-5/8 143	4-3/8 111	53/64 21	1-11/16 43	21/32 17	2-43/64 57.6	63/64 25	3/4 19	5/8 M16	SUC 210-30 210-31 210 210-32	TF 210	1.20	2.79

Thermoplastic SUCTFL 200 Series

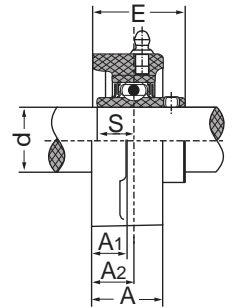
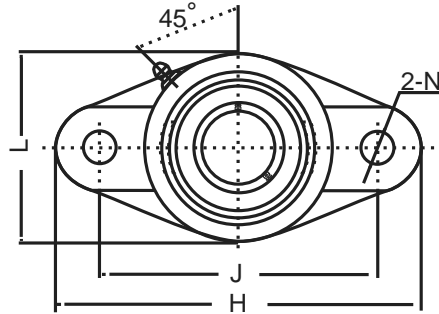

Unit No.	Shaft Diameter (inch / mm)	Dimensions (inch / mm)									Bolt Size	Bearing No.	Housing No.	Mass	
		d	H	J	L	A1	A	N	E	A2				S	kg
SUCTFL 201 201-8 202 202-10 203 204-12 204	12 mm 1/2 15 mm 5/8 17 mm 3/4 20 mm	4-7/16 113	3-35/64 90	2-35/64 65	7/16 11.4	1-3/64 26.5	7/16 11	1-21/64 33.7	39/64 15.5	1/2 12.7	3/8 M10	SUC 201 201-8 202 202-10 203 204-12 204	TFL 204	.29	.71
SUCTFL 205-14 205-15 205 205-16	7/8 15/16 25 mm 1	5-1/8 130	3-57/64 99	2-47/64 69.5	17/32 13.5	1-9/64 29.1	7/16 11	1-29/64 36.7	43/64 17	9/16 14.3	3/8 M10	SUC 205-14 205-15 205 205-16	TFL 205	.34	.80
SUCTFL 206-18 206 206-19 206-20	1-1/8 30 mm 1-3/16 1-1/4	5-13/16 148	4-39/64 117	3-9/64 80	33/64 13.1	1-13/64 30.5	7/16 11	1-5/8 41.4	3/4 19	5/8 15.9	3/8 M10	SUC 206-18 206 206-19 206-20	TFL 206	.54	1.12
SUCTFL 207-20 207-21 207-22 207 207-23	1-1/4 1-5/16 1-3/8 35 mm 1-7/16	6-7/16 164	5-1/8 130	3-35/64 90	5/8 16.1	1-19/64 32.8	33/64 13	1-45/64 43.4	45/64 18	11/16 17.5	1/2 M12	SUC 207-20 207-21 207-22 207 207-23	TFL 207	.78	1.65
SUCTFL 208-24 208-25 208	1-1/2 1-9/16 40 mm	6-7/8 174.5	5-43/64 144	3-15/16 100	25/32 20	1-15/32 37.5	9/16 14	2-1/32 51.7	27/32 21.5	3/4 19	1/2 M12	SUC 208-24 208-25 208	TFL 208	.97	2.15
SUCTFL 209-26 209-27 209-28 209	1-5/8 1-11/16 1-3/4 45 mm	7-7/16 188.5	5-27/32 148.5	4-1/4 108	53/64 21	1-39/64 41	43/64 17	2-9/64 54.2	15/16 24	3/4 19	5/8 M16	SUC 209-26 209-27 209-28 209	TFL 209	1.09	2.45
SUCTFL 210-30 210-31 210 210-32	1-7/8 1-15/16 50 mm 2	7-3/4 197	6-3/16 157	4-33/64 115	53/64 21	1-11/16 43	43/64 17	2-17/64 57.6	63/64 25	3/4 19	5/8 M16	SUC 210-30 210-31 210 210-32	TFL 210	1.20	2.79



Rod Ends

Stainless Steel

Rod Ends Series

SFR_T & SFL_T Series

SMR_T & SML_T Series

SCOM_T

Rod Ends Material

GRB Stainless Steel Rod Ends have a sliding contact surface combination of stainless steel-on-Teflon lining.

Design

GRB Maintenance-Free Rod Ends are of a two-piece design with the 300 series stainless steel housing swaged around a 440C series stainless steel precision-ground spherical ball to provide maximum load capacity. As a rule, rod ends are available with left or right-hand, male or female threads.

Main Purposes

GRB Maintenance-Free Rod Ends have very low friction and can be operated without maintenance. They are used for applications where long bearing life is required without maintenance, or where operating conditions, such as inadequate lubrication or the absence of lubrication make the use of steel-on-steel bearings inadvisable. Maintenance-free bearings are primarily intended for applications where loads are heavy and their direction is constant.

Female Rod Ends

Stainless Steel - SFR_T & SFL_T Series

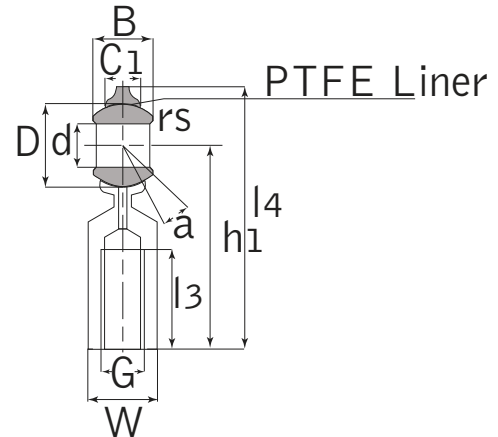
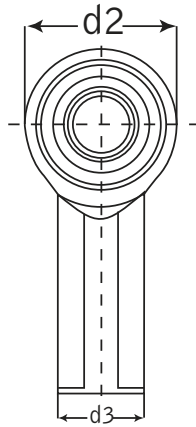

Unit No.		Dimensions (inch / mm)													Load Ratings lbf / N		Mass	
Right-hand	Left-hand	d	B	D	C1	d2	G	h1	l3	l4	W	d3	rs	a	Dynamic Cr	Static C0r	kg	lbs
SFR 3T	SFL 3T	0.190 4.83	0.312 7.92	0.437 11.10	0.25 5.94	0.625 15.88	10-32	1.062 26.97	0.562 12.70	1.375 34.93	0.312 7.92	0.406 10.31	0.012 0.30	10	611 2720	776 3450	0.015	0.033
SFR 4T	SFL 4T	0.250 6.35	0.375 9.53	0.500 12.70	0.281 6.35	0.750 19.05	1/4-28	1.312 33.32	0.750 19.05	1.687 42.85	0.375 9.53	0.469 11.91	0.012 0.30	13	810 3600	1298 5775	0.025	0.055
SFR 5T	SFL 5T	0.313 7.95	0.437 11.10	0.625 15.88	0.344 7.92	0.875 22.23	5/16-24	1.375 34.93	0.750 19.05	1.812 46.02	0.437 11.10	0.500 12.70	0.012 0.30	10	1241 5520	1416 6300	0.036	0.079
SFR 6T	SFL 6T	0.375 9.53	0.500 12.70	0.719 18.26	0.406 10.31	1.000 25.40	3/8-24	1.625 41.28	0.937 23.80	2.125 53.98	0.562 14.27	0.687 17.45	0.024 0.61	9	1618 7200	1585 7050	0.061	0.134
SFR 7T	SFL 7T	0.438 11.13	0.562 14.27	0.812 20.62	0.437 11.10	1.125 28.58	7/16-20	1.812 46.02	1.062 26.97	2.375 60.33	0.625 15.88	0.750 19.05	0.024 0.61	11	1978 8800	2192 9750	0.081	0.178
SFR 8T	SFL 8T	0.500 12.70	0.625 15.88	0.937 23.80	0.500 12.70	1.312 33.32	1/2-20	2.125 53.98	1.187 30.15	2.781 70.64	0.750 19.05	0.875 22.23	0.024 0.61	9	2698 12000	3203 14250	0.133	0.293
SFR 10T	SFL 10T	0.625 15.88	0.750 19.05	1.125 28.58	0.562 12.29	1.500 38.10	5/8-18	2.500 63.50	1.500 31.75	3.250 82.55	0.875 22.23	1.000 25.40	0.024 0.61	11	35975 16000	3541 15750	0.190	0.418
SFR 12T	SFL 12T	0.750 19.05	0.875 22.23	1.312 33.32	0.687 17.45	1.750 44.45	3/4-16	2.875 73.03	1.750 44.45	3.750 95.25	1.000 25.40	1.125 28.58	0.024 0.61	10	5215 23200	4889 21750	0.285	0.627

Other sizes could be available upon request. Minimum quantity may apply.



Male Rod Ends

Stainless Steel - SMR_T & SML_T Series

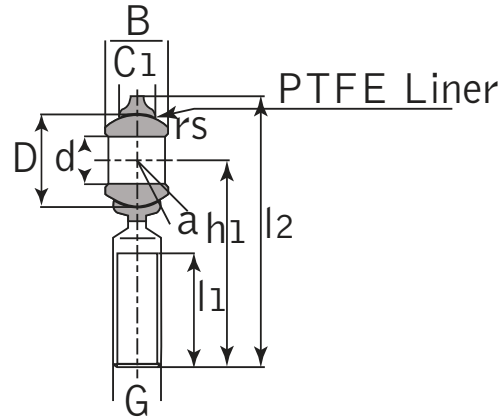
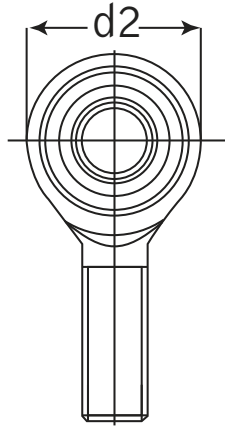

Unit No.		Dimensions (inch / mm)											Load Ratings lbf / N		Mass	
Right-hand	Left-hand	d	B	D	C1	d2	G	h1	l1	l2	rs	a	Dynamic Cr	Static C0r	kg	lbs
SMR 3T	SML 3T	0.190 4.83	0.312 7.92	0.437 11.10	0.234 5.94	0.625 15.88	10-32	1.250 31.75	0.750 19.05	1.563 39.70	0.012 0.30	10.0	611 2720	641 2850	0.014	0.031
SMR 4T	SML 4T	0.250 6.35	0.375 9.53	0.500 12.70	0.250 6.35	0.750 19.05	1/4-28	1.562 39.67	1.000 25.40	1.937 49.20	0.012 0.30	13.5	810 3600	1113 4950	0.018	0.040
SMR 5T	SML 5T	0.313 7.95	0.437 11.10	0.625 15.88	0.312 7.92	0.875 22.23	5/16-24	1.875 47.63	1.250 31.75	2.312 58.72	0.012 0.30	11.0	1241 5520	1416 6300	0.032	0.070
SMR 6T	SML 6T	0.375 9.53	0.500 12.70	0.719 18.26	0.359 9.12	1.000 25.40	3/8-24	1.938 49.23	1.250 31.75	2.438 61.93	0.024 0.61	11.0	1690 7520	16686 7500	0.050	0.110
SMR 7T	SML 7T	0.438 11.13	0.562 14.27	0.812 20.62	0.406 10.31	1.125 28.58	7/16-20	2.125 53.98	1.375 34.93	2.688 68.28	0.024 0.61	10.5	1978 8800	2192 9750	0.068	0.150
SMR 8T	SML 8T	0.500 12.70	0.625 15.88	0.937 23.80	0.453 11.51	1.312 33.32	1/2-20	2.438 61.93	1.500 38.10	3.094 78.59	0.024 0.61	10.0	2698 12000	3203 14250	0.110	0.242
SMR 10T	SML 10T	0.625 15.88	0.75 19.05	1.125 28.58	0.484 12.29	1.500 38.10	5/8-18	2.625 66.68	1.625 41.28	3.375 85.73	0.024 0.61	13.0	3597 16000	3541 15750	0.160	0.352
SMR 12T	SML 12T	0.750 19.05	0.875 22.23	1.312 33.32	0.593 15.06	1.750 44.45	3/4-16	2.875 73.03	1.75 44.45	3.75 95.25	0.024 0.61	12.0	5215 23200	4889 21750	0.260	0.572

Other sizes could be available upon request. Minimum quantity may apply.

Spherical Plain Bearings with PTFE Liner

Stainless Steel - SCOM_T Series

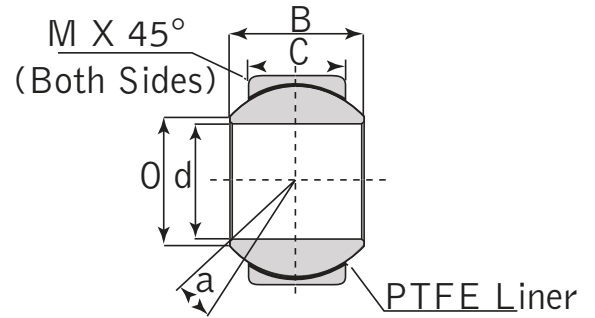
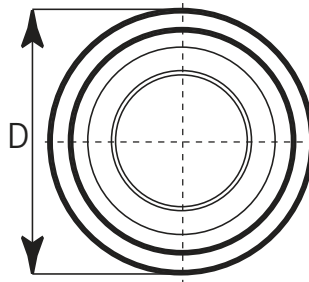

Unit No.	Dimensions (inch / mm)							Ball Diameter Ref.	Load Rating lbf / N static	Mass	
	d	D	C	B	O	M	a			kg	lbs
SCOM 3T	0.1900 4.826	0.5625 14.288	0.218 5.537	0.281 7.137	0.293 7.442	0.020 0.508	11.0	0.406 10.312	3300 14679	0.005	0.01
SCOM 4T	0.2500 6.350	0.6562 16.667	0.250 6.350	0.343 8.712	0.364 9.246	0.022 0.559	13.5	0.500 12.700	5025 22352	0.009	0.02
SCOM 5T	0.3125 7.938	0.7500 19.050	0.281 7.137	0.375 9.525	0.419 10.643	0.032 0.813	12.0	0.562 14.275	6900 30692	0.014	0.03
SCOM 6T	0.3750 9.525	0.8125 20.638	0.312 7.925	0.406 10.312	0.516 13.106	0.032 0.813	10.0	0.656 16.662	9300 41369	0.018	0.04
SCOM 7T	0.4375 11.113	0.9062 23.017	0.343 8.712	0.437 11.100	0.530 13.462	0.032 0.813	8.0	0.687 17.450	11175 49709	0.023	0.05
SCOM 8T	0.5000 12.700	1.0000 25.400	0.390 9.906	0.500 12.700	0.640 16.256	0.032 0.813	9.5	0.813 20.650	13425 59717	0.032	0.07
SCOM 9T	0.5625 14.288	1.0937 27.780	0.437 11.100	0.562 14.275	0.710 18.034	0.032 0.813	9.5	0.906 23.012	17775 79067	0.041	0.09
SCOM 10T	0.6250 15.875	1.1875 30.163	0.500 12.700	0.625 15.875	0.780 19.812	0.032 0.813	8.5	1.000 25.400	24000 106757	0.050	0.11
SCOM 12T	0.7500 19.050	1.4375 36.513	0.593 15.062	0.750 19.050	0.920 23.368	0.044 1.118	9.0	1.187 30.150	36000 160136	0.091	0.20
SCOM 14T	0.875 22.225	1.5625 39.688	0.703 17.856	0.875 22.225	0.980 24.892	0.044 1.118	9.5	1.312 33.325	51750 230195	0.118	0.26
SCOM 16T	1.000 25.400	1.7500 44.450	0.797 20.244	1.000 25.400	1.118 28.397	0.044 1.118	10.0	1.500 38.100	62250 276901	0.177	0.39

Other sizes could be available upon request. Minimum quantity may apply.



Shaft Collars

Stainless Steel

Series

SCSS

2SCSS

Shaft Collar Material

Our shaft collars are made of AISI 303 Austenitic stainless steel. They are ductile, tough and, most importantly, easy to weld. They are also non magnetic.

Solid or Two Piece?

Although economical, Solid Type shaft collars have a reduced holding power and their screw can mar a shaft since it directly fastens on it. Two-Piece shaft collars have about 2-1/2 times the holding power of a Solid Type collar since they can be compressed. Because Two-Piece shaft collars have two tangential screws. They can be installed without having to disturb your initial arrangement.

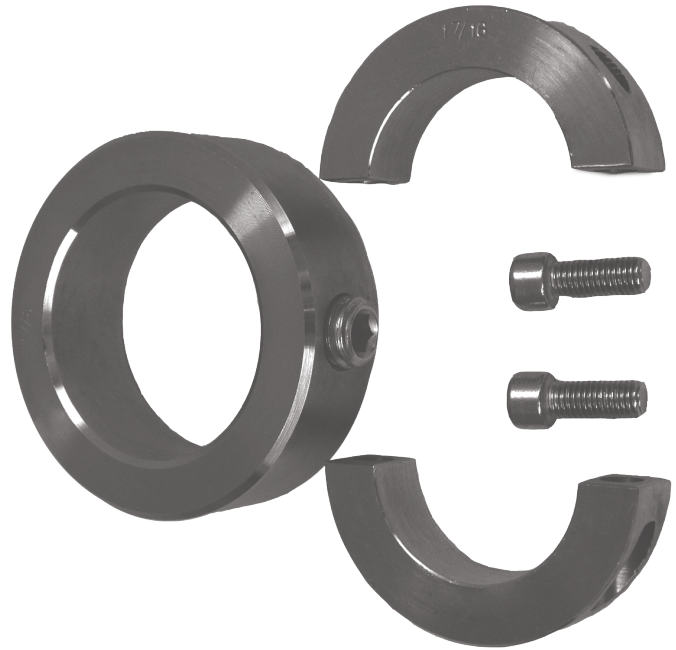

Solid Type Shaft Collars

SCSS Series

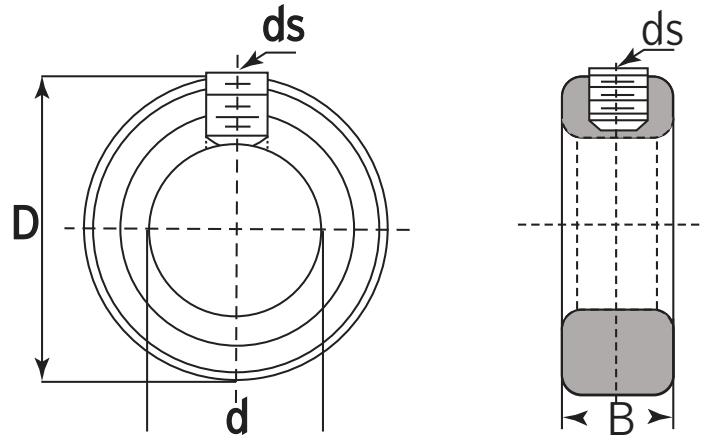

Unit No.	Dimensions (inch)				Mass	
	d	D	B	ds	kg	lbs
SCSS 1/8	0.125	0.375	0.250	6-32	0.003	0.006
3/16	0.188	0.438	0.250	8-32	0.003	0.006
1/4	0.250	0.500	0.313	10-32	0.006	0.013
5/16	0.313	0.625	0.313	10-32	0.009	0.019
3/8	0.375	0.750	0.375	1/4-20	0.014	0.031
SCSS 7/16	0.438	0.875	0.438	1/4-20	0.023	0.050
1/2	0.500	1.000	0.438	1/4-20	0.031	0.069
9/16	0.563	1.000	0.438	1/4-20	0.029	0.063
5/8	0.625	1.125	0.500	5/16-18	0.043	0.094
11/16	0.688	1.250	0.563	5/16-18	0.057	0.125
SCSS 3/4	0.750	1.250	0.563	5/16-18	0.054	0.119
13/16	0.813	1.313	0.563	5/16-18	0.048	0.106
7/8	0.875	1.500	0.563	5/16-18	0.082	0.181
15/16	0.938	1.625	0.563	5/16-18	0.078	0.171
1	1.000	1.625	0.625	5/16-18	0.079	0.174
SCSS 1-1/16	1.063	1.750	0.625	5/16-18	0.116	0.256
1-1/8	1.125	1.750	0.625	5/16-18	0.111	0.244
1-3/16	1.188	2.000	0.688	3/8-16	0.173	0.381
1-1/4	1.250	2.000	0.688	3/8-16	0.162	0.356
1-5/16	1.313	2.125	0.688	3/8-16	0.188	0.413

Other sizes could be available upon request. Minimum quantity may apply.

Unit No.	Dimensions (inch)				Mass	
	d	D	B	ds	kg	lbs
SCSS 1-3/8	1.375	2.125	0.750	3/8-16	0.190	0.419
1-7/16	1.438	2.250	0.750	3/8-16	0.216	0.475
1-1/2	1.500	2.250	0.750	3/8-16	0.205	0.450
1-9/16	1.563	2.500	0.813	3/8-16	0.304	0.669
1-5/8	1.625	2.500	0.813	3/8-16	0.287	0.631
SCSS 1-11/16	1.688	2.500	0.813	3/8-16	0.270	0.594
1-3/4	1.750	2.625	0.875	1/2-13	0.324	0.713
1-13/16	1.813	2.750	0.875	1/2-13	0.361	0.794
1-7/8	1.875	2.750	0.875	1/2-13	0.347	0.763
1-15/16	1.938	3.000	0.875	1/2-13	0.446	0.981
SCSS 2	2.000	3.000	0.875	1/2-13	0.423	0.931
2-1/8	2.125	3.000	0.875	1/2-13	0.378	0.831
2-3/16	2.188	3.250	0.938	1/2-13	0.529	1.163
2-1/4	2.250	3.250	0.938	1/2-13	0.503	1.106
2-5/16	2.313	3.250	0.938	1/2-13	0.051	0.113
SCSS 2-3/8	2.375	3.250	0.938	1/2-13	0.452	0.994
2-7/16	2.438	3.500	1.000	1/2-13	0.620	1.363
2-1/2	2.500	3.500	1.000	1/2-13	0.591	1.300
2-9/16	2.563	3.750	1.125	1/2-13	0.738	1.623
2-5/8	2.625	4.000	1.125	1/2-13	0.980	2.156
SCSS 2-11/16	2.688	4.000	1.125	1/2-13	0.977	2.150
2-3/4	2.750	4.000	1.125	1/2-13	0.952	2.094
2-7/8	2.875	4.250	1.125	1/2-13	0.844	1.856
2-15/16	2.938	4.250	1.125	1/2-13	0.832	1.831
3	3.000	4.250	1.125	1/2-13	0.786	1.730

Other sizes could be available upon request. Minimum quantity may apply.



Two Piece Shaft Collar

2 SCSS Series

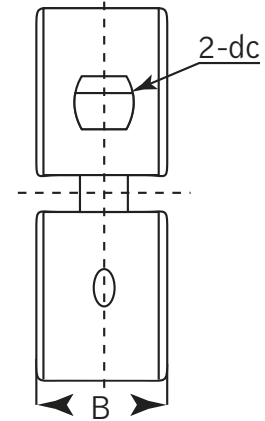
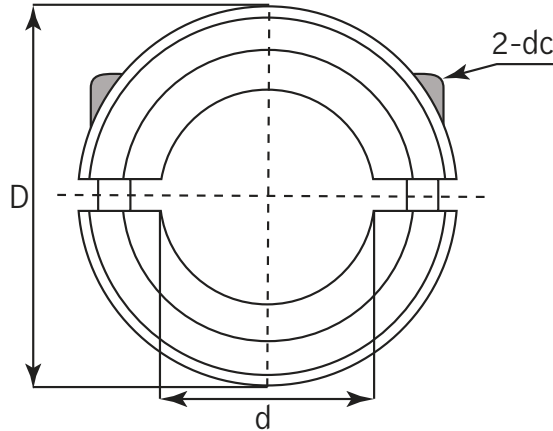

Unit No.	Dimensions (inch)					Mass	
	d	D	B	dc	kg	lbs	
2SCSS	1/8	0.125	0.500	0.250	4-40	0.014	0.030
	3/16	0.188	0.625	0.313	4-40	0.013	0.028
	1/4	0.250	0.688	0.313	4-40	0.012	0.026
	5/16	0.313	0.688	0.313	4-40	0.011	0.025
	3/8	0.375	0.875	0.375	6-32	0.023	0.050
2SCSS	7/16	0.438	0.938	0.375	6-32	0.023	0.051
	1/2	0.500	1.125	0.406	8-32	0.041	0.090
	9/16	0.563	1.250	0.438	10-32	0.040	0.088
	5/8	0.625	1.313	0.438	10-32	0.063	0.138
	11/16	0.688	1.375	0.438	10-32	0.060	0.131
2SCSS	3/4	0.750	1.500	0.500	1/4-28	0.102	0.225
	7/8	0.875	1.625	0.500	1/4-28	0.116	0.256
	15/16	0.938	1.750	0.500	1/4-28	0.111	0.244
	1	1.000	1.750	0.500	1/4-28	0.128	0.281
	1-1/8	1.125	1.875	0.500	1/4-28	0.142	0.313
2SCSS	1-3/16	1.188	2.063	0.500	1/4-28	0.134	0.294
	1-1/4	1.250	2.063	0.500	1/4-28	0.150	0.331
	1-5/16	1.313	2.125	0.563	1/4-28	0.142	0.313
	1-3/8	1.375	2.250	0.563	1/4-28	0.165	0.363
	1-7/16	1.438	2.250	0.563	1/4-28	0.156	0.344
2SCSS	1-1/2	1.500	2.375	0.563	1/4-28	0.176	0.388
	1-3/4	1.750	2.750	0.688	5/16-24	0.327	0.719
	1-15/16	1.938	3.000	0.688	5/16-24	0.381	0.838
	2	2.000	3.000	0.688	5/16-24	0.361	0.794
	2-1/4	2.250	3.250	0.750	5/16-24	0.398	0.875
2SCSS	2-3/8	2.375	3.500	0.750	5/16-24	0.381	0.838
	2-7/16	2.438	3.500	0.750	5/16-24	0.366	0.806
	2-1/2	2.500	3.750	0.875	3/8-24	0.648	1.425
	2-15/16	2.938	4.250	0.875	3/8-24	0.795	1.750
	3	3.000	4.250	0.875	3/8-24	0.756	1.663

Other sizes could be available upon request. Minimum quantity may apply.

Engineering

The right side of the page features two large, curved, grey decorative elements. The upper one is a dark grey, curved shape that starts near the top right and curves downwards and to the left. The lower one is a lighter grey, curved shape that starts near the bottom right and curves upwards and to the left. Both shapes are partially cut off by the right edge of the page.

Data

This catalog is dedicated specifically to applications requiring Stainless Steel parts. For this reason, some of the published data may differ from values associated with SAE 52100 Chrome Bearing Steel.

Dynamic Load and Static Load Ratings

For example, SAE 52100 Chrome Bearing Steel has a hardness of HRC 60 to 64, while AISI 440C Stainless Steel hardness is HRC 58 to 62. Therefore, as a safety factor, we have derated Dynamic Load and Static Load Rating values to 80% and 75% respectively of the values generally associated with SAE 52100 Chrome Steel Bearings.



Clearance

Stainless Steel

Internal Clearance is the total distance, under zero load, through which one ring can move relative to the other. Movement in a radial direction is called radial internal clearance. Movement in an axial direction is called axial internal clearance.

The radial internal clearance of a bearing is greater prior to its installation. The reduction in clearance comes from the expansion of the inner ring or the contraction of the outer ring while they are mounted with an interference fit and from the relative expansion of the bearing due to a rise in temperature during operation.

A mounted ball bearing, running at operating temperature, should show an internal clearance near zero. However, some radial internal clearance for cylindrical, tapered and spherical roller bearings will need to remain under normal operating conditions. This rule is not to be applied in a case requiring a very rigid bearing arrangement as in machine tool spindles.

In order to provide the optimum operating bearing clearance for applications where normal fit and operating conditions apply, the standard Internal Radial Clearance values have been established. For bearings running under other conditions, which requires that both outer and inner rings be mounted with an interference fit, non-standard radial internal clearance bearings should be considered and the net clearance remaining after mounting should be checked.

Bearings having other than standard clearances are represented by suffixes C1 through C5 as follow:

C1: Smaller than C2 Internal Clearance

C2: Smaller than Standard Internal Clearance

STANDARD: Neither the bearing or packaging shows a clearance marking

C3: Larger than Standard Internal Clearance

C4: Larger than C3 Internal Clearance

C5: Larger than C4 Internal Clearance

The internal clearance groups which conform to the International Standards Organization (ISO) as well as the Anti-Friction Bearing Manufacturers Association (AFBMA) standards are specified in the following Tables. Note that these values concern bearings prior to assembly and under zero load.

Applications using miniature ball bearings showing a bore diameter under 10mm exploit a similar system:

A tight radial internal clearance would be expressed as MC1 or MC2 for metric bearings and P02 or P13 for inch size bearings.

A medium radial internal clearance would be expressed as MC3 or MC4 for metric bearings and P24 or P35 for inch size bearings.

A loose radial internal clearance would be expressed as MC5 or MC6 for metric bearings and P58 or P811 for inch size bearings.

Radial Internal Clearance

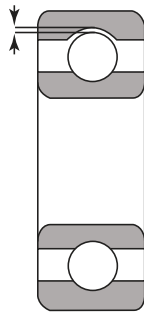

Axial Internal Clearance

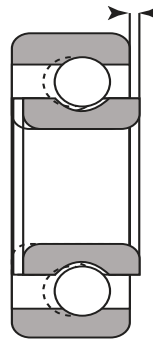

Radial Internal Clearance Conversion Chart

Metric 0.001mm	Inch 0.0001"
MC1 0-5	P02 0-2
MC2 3-8	P13 1-3
MC3 5-10	P24 2-4
MC4 8-13	P35 3-5
MC5 13-20	P58 5-8
MC6 20-28	P811 8-11

Radial Internal Clearances

Single Row Deep Groove Ball - Cylindrical Bore - Inch



Bore Diameter d (Metric)		C2		STANDARD (No Marking) C0		C3		C4		C5	
Over	Incl.	min.	max.	min.	max.	min.	max.	min.	max.	min.	max.
2.5	6	-	0.0003	0.0001	0.0005	0.0003	0.0009	0.0005	0.0012	0.0008	0.0014
6	10	-	0.0003	0.0001	0.0005	0.0003	0.0009	0.0005	0.0012	0.0009	0.0018
10	18	-	0.00035	0.0001	0.0007	0.0004	0.0010	0.0007	0.0013	0.0010	0.0019
18	24	-	0.0004	0.0002	0.0008	0.0005	0.0011	0.0008	0.0014	0.0011	0.0018
24	30	0.00005	0.00045	0.0002	0.0008	0.0005	0.0011	0.0009	0.0016	0.0012	0.0021
30	40	0.00005	0.00045	0.0002	0.0009	0.0006	0.0013	0.0011	0.0018	0.0015	0.0025
40	50	0.00005	0.00045	0.0002	0.0009	0.0007	0.0014	0.0012	0.0020	0.0017	0.0029
50	65	0.00005	0.0006	0.0003	0.0011	0.0009	0.0017	0.0015	0.0024	0.0021	0.0035
65	80	0.00005	0.0006	0.0004	0.0012	0.0010	0.0020	0.0018	0.0028	0.0025	0.0041
80	100	0.00005	0.0007	0.0005	0.0014	0.0012	0.0023	0.0021	0.0033	0.0030	0.0047
100	120	0.00010	0.0008	0.0006	0.0016	0.0014	0.0026	0.0024	0.0038	0.0035	0.0055
120	140	0.00010	0.0009	0.0007	0.0019	0.0016	0.0032	0.0028	0.0045	0.0041	0.0063
140	160	0.00010	0.0009	0.0007	0.0021	0.0018	0.0036	0.0032	0.0051	0.0045	0.0071
160	180	0.00010	0.0010	0.0008	0.0024	0.0021	0.0040	0.0036	0.0058	0.0052	0.0079
180	200	0.00010	0.0012	0.0010	0.0028	0.0025	0.0046	0.0042	0.0064	0.0058	0.0090

Bore Diameter d (Metric)		C2		STANDARD (No Marking) C0		C3		C4		C5	
Over	Incl.	min.	max.	min.	max.	min.	max.	min.	max.	min.	max.
200	225	0.00010	0.0012	0.0011	0.0032	0.0028	0.0052	0.0047	0.0073	0.0068	0.0100
225	250	0.00010	0.0014	0.0012	0.0036	0.0034	0.0059	0.0055	0.0085	0.0080	0.0114
250	280	0.00010	0.0015	0.0014	0.0038	0.0038	0.0064	0.0059	0.0093	0.0088	0.0126
280	315	0.00030	0.0017	0.0016	0.0043	0.0043	0.0070	0.0068	0.0102	0.0102	0.0141
315	355	0.00030	0.0019	0.0019	0.0047	0.0047	0.0078	0.0078	0.0114	0.0114	0.0159
355	400	0.00030	0.0023	0.0023	0.0055	0.0055	0.0090	0.0090	0.0130	0.0130	0.0181
400	450	0.00040	0.0027	0.0027	0.0063	0.0063	0.0102	0.0102	0.0145	0.0130	0.0204
450	500	0.00040	0.0031	0.0031	0.0070	0.0070	0.0114	0.0114	0.0161	0.0130	0.0224
500	560	0.00070	0.0035	0.0035	0.0078	0.0078	0.0126	0.0126	0.0181	0.0130	0.0248
560	630	0.00070	0.0039	0.0039	0.0086	0.0086	0.0137	0.0137	0.0200	0.0130	0.0275
630	710	0.00110	0.0047	0.0047	0.0098	0.0098	0.0153	0.0153	0.0220	0.0130	0.0307
710	800	0.00110	0.0051	0.0051	0.0110	0.0110	0.0173	0.0173	0.0240	0.0130	0.0338
800	900	0.00110	0.0059	0.0059	0.0122	0.0122	0.0193	0.0193	0.0271	0.0130	0.0378
900	1000	0.00150	0.0063	0.0063	0.0133	0.0133	0.0212	0.0212	0.0299	0.0130	0.0409



Fit Charts

Shaft Fits

Bearing Type	Load Conditions (please refer to figure 1.1 on page 39)		Ball Bearings	Cylindrical and Tapered Ball Bearings	Spherical Roller Bearings	Shaft Fits	
			Shaft Diameter (mm)				
Cylindrical Bore Bearings	Rotating Inner Ring or Indeterminate Direction Load	Light or fluctuating variable load	-18	-	-	h5	
			18 - 100	-40	-	js6	
			100 - 200	40 - 140	-	k6	
			-	140 - 200	-	m6	
		Normal to heavy load	-18	-	-	js5	
			18 - 100	-40	-40	k5	
			100 - 140	40 - 100	40 - 65	m5	
			140 - 200	100 - 140	65 - 100	m6	
			200 - 280	140 - 200	100 - 140	n6	
			-	200 - 400	140 - 280	p6	
			-	-	280 - 500	r6	
			-	50 - 140	50 - 100	n6	
	Very heavy or shock load	-	140 - 200	100 - 140	p6		
		-	200 -	140 -	r6		
		Static Inner Ring Load	Inner ring axial displacement required	All shaft diameters			g6
			Easy axial displacement of inner ring not required	All shaft diameters			h6

Housing Fits

Housing Type	Load Conditions		Housing Fit
Solid or split housing	Outer ring static load	All load conditions	H7
		Heat conducted through shaft	G7
Solid housing	Direction indeterminate load	Light to normal	JS7
		Normal to heavy load	K7
		heavy shock load	M7
	Outer ring rotating load	Light or variable load	M7
		Normal to heavy load	N7
		Heavy load (thin wall housing) Heavy shock load	P7

Fit Charts

Fitting Values for Shaft (μm)



Nominal Bore Diameter d		Tolerance of Bore Diameter (μm)		g5	g6	h5	h6	j5	js5	j6
Over	Incl.	High	Low	Bearing Shaft	Bearing Shaft	Bearing Shaft	Bearing Shaft	Bearing Shaft	Bearing Shaft	Bearing Shaft
3	6	0	-8	-4 +9	-4 +12	-8 +5	-8 +8	-11 +2	-10.5 +2.5	-14 +2
6	10	0	-8	-3 +11	-3 +14	-8 +6	-8 +9	-12 +2	-11 +3	-15 +2
10	18	0	-8	-2 +14	-2 +17	-8 +8	-8 +11	-13 +3	-12 +4	-16 +3
18	30	0	-10	-3 +16	-3 +20	-10 +9	-10 +13	-15 +4	-14.5 +4.5	-19 +4
30	50	0	-12	-3 +20	-3 +25	-12 +11	-12 +16	-18 +5	-17.5 +5.5	-23 +5
50	80	0	-15	-5 +23	-5 +29	-15 +13	-15 +19	-21 +7	-21.5 +6.5	-27 +7
80	120	0	-20	-8 +27	-8 +34	-20 +15	-20 +22	-26 +9	-27.5 +7.5	-33 +9
120	140	0	-25	-11 +32	-11 +39	-25 +18	-25 +25	-32 +11	-34 +9	-39 +11
140	160	0								
160	180	0								
180	200	0	-30	-15 +35	-15 +44	-30 +20	-30 +29	-37 +13	-40 +10	-46 +13
200	225	0								
225	250	0								
250	280	0	-35	-18 +40	-18 +49	-35 +23	-35 +32	-42 +16	-46.5 +11.5	-51 +16
280	315	0								
315	355	0								
355	400	0	-40	-22 +54	-22 +54	-40 +25	-40 +36	-47 +18	-52.5 +12.5	-58 +18
400	450	0								
450	500	0								
450	500	0	-45	-25 +60	-25 +60	-45 +27	-45 +40	-52 +20	-58.5 +13.5	-65 +20
450	500	0								
450	500	0								
Nominal Bore Diameter d		Tolerance of Bore Diameter (μm)		js6	k5	k6	m6	n6	p6	r6
Over	Incl.	High	Low	Bearing Shaft	Bearing Shaft	Bearing Shaft	Bearing Shaft	Bearing Shaft	Bearing Shaft	Bearing Shaft
3	6	0	-8	-12 +4	-14 -1	-17 -1	-20 -4	-24 -8	-28 -12	--
6	10	0	-8	-12.5 +4.5	-15 -1	-18 -1	-23 -6	-27 -10	-32 -15	--
10	18	0	-8	-13.5 +5.5	-17 -1	-20 -1	-26 -7	-31 -12	-37 -18	--
18	30	0	-10	-16.5 +6.5	-21 -2	-25 -2	-31 -8	-38 -15	-45 -22	--
30	50	0	-12	-20 +8	-25 -2	-30 -2	-37 -9	-45 -17	-54 -26	--
50	80	0	-15	-24.5 +9.5	-30 -2	-36 -2	-45 -11	-54 -20	-66 -32	--
80	120	0	-20	-31 +11	-38 -3	-45 -3	-55 -13	-65 -23	-79 -37	--
120	140	0	-25	-37.5 +12.5	-46 -3	-53 -3	-65 -15	-77 -27	-93 -43	-113 -63
140	160	0								
160	180	0								
180	200	0	-30	-44.5 +14.5	-54 -4	-63 -4	-76 -17	-90 -31	-109 -50	-136 -77
200	225	0								
225	250	0								
250	280	0	-35	-54 +16	-62 -4	-71 -4	-87 -20	-101 -34	-123 -56	-161 -94
280	315	0								
315	355	0								
355	400	0	-40	-58 +18	-69 -4	-80 -4	-97 -21	-113 -37	-138 -62	-184 -108
400	450	0								
450	500	0								
450	500	0	-45	-65 +20	-77 -5	-90 -4	-108 -23	-125 -40	-153 -68	-211 -126
450	500	0								
450	500	0								

Note: (+) numbers indicate loose fits. (-) numbers indicate tight fits.



Fit Charts

Fitting Values for Housing (μm)

Nominal Bore Diameter d		Tolerance of Bore Diameter (μm)		G7	H6	H7	J6	J7	Js7	K6
over	incl.	High	Low	Housing Bearing	Housing Bearing	Housing Bearing	Housing Bearing	Housing Bearing	Housing Bearing	Housing Bearing
6	10	0	-8	+ 5 +28	0 +17	0 +23	-4 +13	-7 +16	-7.5 +15.5	- 7 +10
10	18	0	-8	+6 +32	0 +19	0 +26	-5 +14	-8 +18	-9 +17	-9 +10
18	30	0	-9	+7 +37	0 +22	0 +30	-5 +17	-9 +21	-10.5 +19.5	-11 +11
30	50	0	-11	+9 +45	0 +27	0 +36	-6 +21	-11 +25	-12.5 +23.5	-13 +14
50	80	0	-13	+10 +53	0 +32	0 +43	-6 +26	-12 +31	-15 +28	-15 +17
80	120	0	-15	+12 +62	0 +37	0 +50	-6 +31	-13 +37	-17.5 +32.5	-18 +19
120	150	0	-18	+14 +72	0 +43	0 +58	-7 +36	-14 +44	-20 +38	-21 +22
150	180	0	-25	+14 +79	0 +50	0 +65	-7 +43	-14 +51	-20 +45	-21 +29
180	250	0	-30	+15 +91	0 +59	0 +76	-7 +52	-16 +60	-23 +53	-24 +35
250	315	0	-35	+17 +104	0 +67	0 +87	-7 +60	-16 +71	-26 +61	-27 +40
315	400	0	-40	+18 +115	0 +76	0 +97	-7 +69	-18 +79	-28.5 +68.5	-29 +47
400	500	0	-45	+20 +128	0 +75	0 +108	-7 +78	-20 +88	-31.5 +76.5	-32 +53
Nominal Bore Diameter d		Tolerance of Bore Diameter (μm)		K7	M7	N7	P7			
over	incl.	High	Low	Housing Bearing	Housing Bearing	Housing Bearing	Housing Bearing			
6	10	0	-8	-10 +13	-15 +8	-19 +4	-24 -1			
10	18	0	-8	-12 +14	-18 +8	-23 +3	-29 -3			
18	30	0	-9	-15 +15	-21 +9	-28 +2	-35 -3			
30	50	0	-11	-18 +18	-25 +11	-33 +3	-42 -6			
50	80	0	-13	-21 +22	-30 +13	-39 +4	-51 -8			
80	120	0	-15	-25 +25	-35 +15	-45 +5	-59 -9			
120	150	0	-18	- 28 +30	-40 +18	-52 +6	-68 -10			
150	180	0	-25	-28 +37	-40 +25	-52 +13	-68 -3			
180	250	0	-30	-33 +43	-46 +30	-60 +16	-79 -3			
250	315	0	-35	-36 +51	-52 +35	-66 +21	-88 -3			
315	400	0	-40	-40 +57	-57 +40	-73 +24	-98 -1			
400	500	0	-45	-45 +63	-63 +45	-80 +28	-108 -0			

Note: (+) numbers indicate loose fits. (-) numbers indicate tight fits.

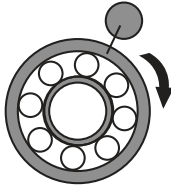

Figure 1.1

Bearing Rotation And Load	Illustration	Ring Load	Fit
Inner ring: rotating Outer ring: stationary Load direction: constant	Static load	Rotating inner ring load	Inner ring: Tight fit
Inner ring: stationary Outer ring: rotating Load direction: rotates with outer ring	Unbalanced load	Static outer ring load	Outer ring: Loose fit
Inner ring: stationary Outer ring: rotating Load direction: constant	Static load	Static inner ring load	Inner ring: Loose fit
Inner ring: rotating Outer ring: stationary Load direction: rotates with outer ring	Unbalanced load	Rotating outer ring load	Outer ring: Tight fit



Static Load



Unbalanced Load

Figure 1.2

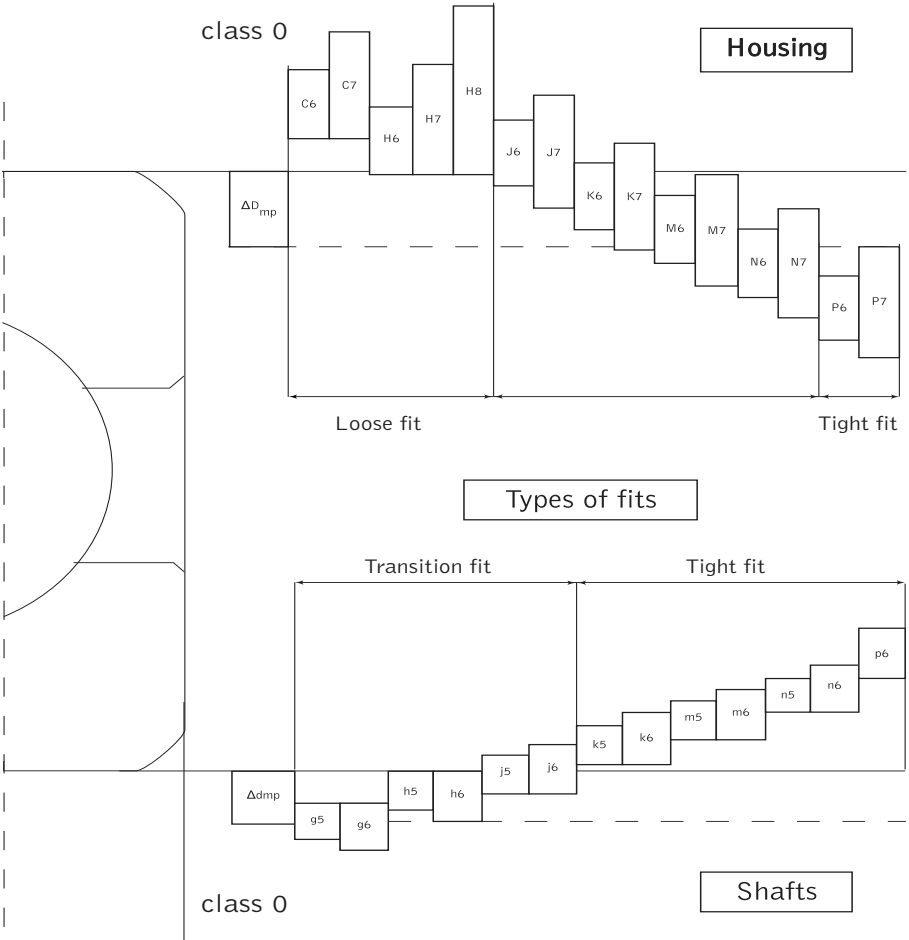



Bearing Tolerances

Stainless Steel

Metric Bearings

The Tolerances indicated on the following pages conform to the Anti-Friction Bearing Manufacturers Association (AFBMA) and the International Standards Organization (ISO) standards.

These bearings are available in Tolerance Classes. STANDARD (ABEC-1) (no markings):

P/6 (ABEC-3). P/5 (ABEC-5) and P/4 (ABEC-7).

Bearings in Tolerance Classes P/5 (ABEC-5) and P/4 (ABEC-7) are ideal for special applications such as machine tool spindles.

We keep the ABEC-1 Standard bearings in stock.

Inch Bearings

Our inch series of bearings are only available in STANDARD Tolerance Class (no markings), which conform to British Standards for external dimension limits and running accuracy. To clarify the headings and symbols used in these Tolerance Tables, the following definitions will apply:

d = Nominal bearing bore diameter.

d_{min} = The minimum diameter reading obtained by two-point measurements of a bearing bore having out-of-roundness and taper.

d_{max} = The maximum diameter reading obtained by two-point measurements of a bearing bore having out-of-roundness and taper.

d_m = $(d_{max} + d_{min} / 2)$ for a particular bearing.

D = Nominal bearing outside diameter.

D_{min} = The minimum diameter reading obtained by two-point measurements of a bearing outside surface having out-of-roundness and taper.

D_{max} = The maximum diameter reading obtained by two-point measurements of a bearing outside surface having out-of-roundness and taper.

D_m = $(D_{max} + D_{min} / 2)$ for a particular bearing
A bearing ring width is the distance between the points of intersection between the two sides of the ring and a straight line perpendicular to one of the sides.

B = Width of bearing.

Bearing Tolerance

Radial Bearings - Metric (Except Tapered Roller Bearings)



Tolerance Class - STANDARD (ABEC-1)							
Inner Ring Nominal Bore Diameter (Metric)		Bore Tolerances (inch)				Width Tolerances (inch)	
d		dm		d min	d max	B	
Over	Incl.	Low	High	Minimum	Maximum	Maximum	Minimum
2.5	10	-0.00030	0	-0.00040	0.00010	0	-0.00450
10	18	-0.00030	0	-0.00040	0.00010	0	-0.00450
18	30	-0.00040	0	-0.00050	0.00010	0	-0.00450
30	50	-0.00050	0	-0.00060	0.00010	0	-0.00450
50	80	-0.00060	0	-0.0008	0.0002	0	-0.00600
80	120	-0.00080	0	-0.00100	0.00020	0	-0.00800
120	180	-0.00100	0	-0.00120	0.0003	0	-0.01000
180	250	-0.00120	0	-0.00150	0.00030	0	-0.01200
250	315	-0.00140	0	-0.00170	0.0004	0	-0.01400
315	400	-0.00160	0	-0.00200	0.00040	0	-0.01550
400	500	-0.00180	0	-0.00220	0.00050	0	-0.01750
500	630	-0.00200	0	-0.00250	0.0006	0	-0.02000
630	800	-0.00295	0	-0.00350	0.00060	0	-0.02950
800	1000	-0.00390	0	-0.00470	0.00080	0	-0.03950
Tolerance Class - P/6 (ABEC-3)							
Inner Ring Nominal Bore Diameter (Metric)		Bore Tolerances (inch)				Width Tolerances (inch)	
d		dm		d min	d max	B	
Over	Incl.	Low	High	Minimum	Maximum	Maximum	Minimum
2.5	10	-0.00030	0	-0.00030	0.0001	0	-0.00450
10	18	-0.00030	0	-0.00030	0.0001	0	-0.00450
18	30	-0.00030	0	-0.0004	0.0001	0	-0.00450
30	50	-0.00040	0	-0.00040	0.0001	0	-0.00450
50	80	-0.00050	0	-0.0006	0.00010	0	-0.00600
80	120	-0.00060	0	-0.00070	0.00010	0	-0.00800
120	180	-0.00070	0	-0.00080	0.00010	0	-0.01000
180	250	-0.00090	0	-0.00100	0.0002	0	-0.01200
250	315	-0.00100	0	-0.00120	0.00020	0	-0.01400
315	400	-0.00120	0	-0.00140	0.00020	0	-0.01550
400	500	-0.00140	0	-0.00160	0.0003	0	-0.01750
500	630	-0.00160	0	-0.00190	0.00030	0	-0.02000

Tolerance Class - P/5 (ABEC-5)							
Inner Ring Nominal Bore Diameter (Metric)		Bore Tolerances (inch)				Width Tolerances (inch)	
d		dm		d min	d max	B	
Over	Incl.	Low	High	Minimum	Maximum	Maximum	Minimum
2.5	10	-0.00020	0	-0.00020	0	0	-0.0016
10	18	-0.00020	0	-0.00020	0	0	-0.0032
18	30	-0.00025	0	-0.0003	0	0	-0.00450
30	50	-0.00030	0	-0.00030	0	0	-0.00450
50	80	-0.00035	0	-0.0004	0	0	-0.00600
80	120	-0.00040	0	-0.00040	0	0	-0.00800
120	180	-0.00050	0	-0.00050	0	0	-0.01000
180	250	-0.00060	0	-0.00060	0	0	-0.01200
250	315	-0.00070	0	-0.00070	0	0	-0.01400
315	400	-0.00090	0	-0.00090	0	0	-0.01550
Tolerance Class - P/4 (ABEC-7)							
Inner Ring Nominal Bore Diameter (Metric)		Bore Tolerances (inch)				Width Tolerances (inch)	
d		dm		d min	d max	B	
Over	Incl.	Low	High	Minimum	Maximum	Maximum	Minimum
2.5	10	-0.00015	0	-0.0002	0	0	-0.0016
10	18	-0.00015	0	-0.0002	0	0	-0.0032
18	30	-0.00020	0	-0.00020	0	0	-0.00450
30	50	-0.00025	0	-0.0003	0	0	-0.00450
50	80	-0.00030	0	-0.00030	0	0	-0.00600
80	120	-0.00030	0	-0.00030	0	0	-0.00800
120	180	-0.00040	0	-0.00040	0	0	-0.01000
180	250	-0.00050	0	-0.00050	0	0	-0.01200



Bearing Tolerances

Radial Bearings - Metric (Except Tapered Roller Bearings)

Tolerance Class - STANDARD (ABEC-1)						
Outer Ring Nominal OO.D0. Diameter (Metric)		Outside Diameter Tolerances (inch)				Width Tolerances (inch)
D		DM		D min	D max	B
Over	Incl.	High	Low	Maximum	Minimum	
6	18	0	-0.00030	0.00010	-0.00040	Tolerances are identical to those of inner ring of the same bearing
18	30	0	-0.0004	0.00010	-0.00040	
30	50	0	-0.00040	0.00010	-0.0006	
50	80	0	-0.00050	0.00015	-0.00070	
80	120	0	-0.00060	0.00020	-0.00080	
120	150	0	-0.00070	0.0003	-0.00095	
150	180	0	-0.00100	0.00030	-0.0013	
180	250	0	-0.00120	0.00030	-0.00150	
250	315	0	-0.00140	0.0004	-0.00170	
315	400	0	-0.00160	0.00040	-0.00200	
400	500	0	-0.00180	0.00050	-0.00225	
500	630	0	-0.00200	0.0006	-0.00250	
630	800	0	-0.00295	0.00070	-0.00360	
800	1000	0	-0.00390	0.00080	-0.00470	

Tolerance Class - P/6 (ABEC-3)						
Outer Ring Nominal OO.D0. Diameter (Metric)		Outside Diameter Tolerances (inch)				Width Tolerances (inch)
D		DM		D min	D max	B
Over	Incl.	High	Low	Maximum	Minimum	
6	18	0	-0.00030	0.0001	-0.00030	Tolerances are identical to those of inner ring of the same bearing
18	30	0	-0.00030	0.0001	-0.0004	
30	50	0	-0.0004	0.00010	-0.00040	
50	80	0	-0.00040	0.00010	-0.00050	
80	120	0	-0.00050	0.00010	-0.00060	
120	150	0	-0.00060	0.00010	-0.00070	
150	180	0	-0.00070	0.00010	-0.00080	
180	250	0	-0.00080	0.0002	-0.0010	
250	315	0	-0.00100	0.0002	-0.0012	
315	400	0	-0.00110	0.00020	-0.00130	
400	500	0	-0.00130	0.00020	-0.00150	
500	630	0	-0.00150	0.00020	-0.00180	
630	800	0	-0.00180	0.00040	-0.00220	

Tolerance Class - P/5 (ABEC-5)						
Outer Ring Nominal OO.D0. Diameter (Metric)		Outside Diameter Tolerances (inch)				Width Tolerances (inch)
D		DM		D min	D max	B
Over	Incl.	High	Low	Maximum	Minimum	
6	18	0	-0.00020	0	-0.00020	Tolerances are identical to those of inner ring of the same bearing
18	30	0	-0.0003	0	-0.0003	
30	50	0	-0.00030	0	-0.00030	
50	80	0	-0.0004	0	-0.0004	
80	120	0	-0.00040	0	-0.00040	
120	150	0	-0.00040	0	-0.00040	
150	180	0	-0.00050	0	-0.00050	
180	250	0	-0.00060	0	-0.00060	
250	315	0	-0.00070	0	-0.00070	
315	400	0	-0.00080	0	-0.00080	
400	500	0	-0.00090	0	-0.00090	
500	630	0	-0.00110	0	-0.00110	
630	800	0	-0.00140	0	-0.00140	

Tolerance Class - P/4 (ABEC-7)						
Outer Ring Nominal OO.D0. Diameter (Metric)		Outside Diameter Tolerances (inch)				Width Tolerances (inch)
D		DM		D min	D max	B
Over	Incl.	High	Low	Maximum	Minimum	
6	18	0	-0.0002	0	-0.0002	Tolerances are identical to those of inner ring of the same bearing
18	30	0	-0.00020	0	-0.00020	
30	50	0	-0.0003	0	-0.0003	
50	80	0	-0.00030	0	-0.00030	
80	120	0	-0.00030	0	-0.00030	
120	150	0	-0.0004	0	-0.0004	
150	180	0	-0.00040	0	-0.00040	
180	250	0	-0.00040	0	-0.00040	
250	315	0	-0.00050	0	-0.00050	
315	400	0	-0.00060	0	-0.00060	

Bearing Tolerance



Radial Bearings - Inch (Except Tapered Roller Bearings)

Inner Ring					
Nominal Bore Diameter (inch)		Bore Tolerances (inch)		Width Tolerances (inch)	
d		dm		B	
Over	Incl.	Low	High	Maximum	Minimum
0	1	-0.0002	0.0002	0	-0.005
1	2	-0.0003	0.0002	0	-0.005
2	3	-0.0003	0.0002	0	-0.005
3	6	-0.0003	0.0002	0	-0.005
6	8	-0.0005	0.0002	0	-0.005
8	12	-0.0005	0.0002	0	-0.010
12	15	-0.0008	0.0002	0	-0.016

Outer Ring					
Nominal O.D. Diameter (inch)		Outside Diameter Tolerances (inch)		Width Tolerances (inch)	
d		dm		B	
Over	Incl.	High	Low	Maximum	Minimum
0	1	-0.0003	-0.0007	Tolerances are identical to those of inner ring of the same bearing	
1	2	-0.0003	-0.0008		
2	3	-0.0005	-0.0010		
3	5	-0.0008	-0.0013		
5	8	-0.0013	-0.0018		
8	12	-0.0013	-0.0018		
12	15	-0.0013	-0.0023		

1600 Series Radial Bearings - Inch

Inner Ring					
Nominal Bore Diameter (inch)		Bore Tolerances (inch)		Width Tolerances (inch)	
d		d		B	
Over	Incl.	Low	High	Max.	Min.
0»	5/8 «	-0.0003	0	0	-0.005
5/8 «	1 1/8 «	-0.0004	0	0	-0.005
1 1/8 «	1 5/16 «	-0.0005	0	0	-0.005

Outer Ring					
Nominal O.D. Diameter (inch)		O.D. Tolerances (inch)		Width Tolerances (inch)	
D		D		B	
Over	Incl.	Low	High	Max.	Min.
0»	1 1/6»	-0.0004	0	0	-0.005
1 1/8»	2 9/16»	-0.0005	0	0	-0.005



Conversion Charts

Millimeters to Inches

mm	inches	mm	inches	mm	inches	mm	inches	mm	inches	mm	inches	mm	inches	mm	inches	mm	inches	mm	inches
1	0.039	11	0.433	21	0.827	31	1.221	41	1.614	51	2.008	61	2.402	71	2.795	81	3.189	91	3.583
2	0.079	12	0.472	22	0.866	32	1.260	42	1.654	52	2.047	62	2.441	72	2.835	82	3.228	92	3.622
3	0.118	13	0.512	23	0.906	33	1.299	43	1.693	53	2.087	63	2.480	73	2.874	83	3.268	93	3.661
4	0.158	14	0.551	24	0.945	34	1.339	44	1.732	54	2.165	64	2.520	74	2.913	84	3.307	94	3.701
5	0.197	15	0.591	25	0.984	35	1.378	45	1.772	55	2.205	65	2.559	75	2.953	85	3.347	95	3.740
6	0.236	16	0.630	26	1.024	36	1.417	46	1.811	56	2.205	66	2.598	76	2.992	86	3.386	96	3.780
7	0.276	17	0.6696	27	1.063	37	1.457	47	1.850	57	2.244	67	2.638	77	3.032	87	3.425	97	3.819
8	0.315	18	0.709	28	1.102	38	1.496	48	1.890	58	2.284	68	2.677	78	3.071	88	3.465	98	3.858
9	0.354	19	0.748	29	1.142	39	1.535	49	1.929	59	2.323	69	2.717	79	3.110	89	3.504	99	3.898
10	0.394	20	0.787	30	1.181	40	1.575	50	1.969	60	2.362	70	2.756	80	3.150	90	3.543	100	3.937
mm	inches	mm	inches	mm	inches	mm	inches	mm	inches	mm	inches	mm	inches	mm	inches	mm	inches	mm	inches
101	3.976	111	4.370	121	4.764	131	5.158	141	5.551	151	5.945	161	6.339	171	6.732	181	7.126	191	7.520
102	4.016	112	4.409	122	4.803	132	5.197	142	5.591	152	5.984	162	6.378	172	6.772	182	7.165	192	7.559
103	4.055	113	4.449	123	4.843	133	5.236	143	5.630	153	6.024	163	6.417	173	6.811	183	7.205	193	7.598
104	4.095	114	4.488	124	4.882	134	5.276	144	5.669	154	6.063	164	6.457	174	6.850	184	7.244	194	7.638
105	4.134	115	4.528	125	4.921	135	5.315	145	5.709	155	6.102	165	6.496	175	6.890	185	7.284	195	7.677
106	4.173	116	4.567	126	4.961	136	5.354	146	5.748	156	6.142	166	6.535	176	6.929	186	7.323	196	7.717
107	4.213	117	4.606	127	5.000	137	5.394	147	5.787	157	6.181	167	6.575	177	6.969	187	7.362	197	7.756
108	4.252	118	4.646	128	5.039	138	5.433	148	5.827	158	6.221	168	6.614	178	7.008	188	7.402	198	7.795
109	4.291	119	4.685	129	5.079	139	5.472	149	5.866	159	6.260	169	6.654	179	7.047	189	7.441	199	7.835
110	4.331	120	4.724	130	5.118	140	5.512	150	5.906	160	6.299	170	6.693	180	7.087	190	7.480	200	7.874
mm	inches	mm	inches	mm	inches	mm	inches	mm	inches	mm	inches	mm	inches	mm	inches	mm	inches	mm	inches
201	7.913	211	8.307	221	8.701	231	9.095	241	9.488	251	9.882	261	10.276	271	10.669	281	11.063	291	11.457
202	7.953	212	8.346	222	8.740	232	9.134	242	9.528	252	9.921	262	10.315	272	10.709	282	11.102	292	11.496
203	7.992	213	8.386	223	8.780	233	9.173	243	9.567	253	9.961	263	10.354	273	10.748	283	11.142	293	11.535
204	8.032	214	8.425	224	8.819	234	9.213	244	9.606	254	10.000	264	10.394	274	10.787	284	11.181	294	11.574
205	8.071	215	8.465	225	8.858	235	9.252	245	9.646	255	10.039	265	10.443	275	10.827	285	11.221	295	11.614
206	8.110	216	8.504	226	8.898	236	9.291	246	9.685	256	10.079	266	10.472	276	10.866	286	11.260	296	11.654
207	8.150	217	8.543	227	8.937	237	9.331	247	9.724	257	10.118	267	10.512	277	10.906	287	11.299	297	11.693
208	8.189	218	8.583	228	8.976	238	9.370	248	9.764	258	10.158	268	10.551	278	10.945	288	11.339	298	11.732
209	8.228	219	8.622	229	9.016	239	9.409	249	9.803	259	10.197	269	10.591	279	10.984	289	11.378	299	11.772
210	8.268	220	8.661	230	9.055	240	9.449	250	9.843	260	10.236	270	10.630	280	11.024	290	11.417	300	11.811

Conversion Charts

Stainless Steel



Fractions to Decimals			
Inches		Inches	
fraction	decimal	fraction	decimal
1/64	0.0156	33/64	0.5156
1/32	0.0312	17/32	0.5312
3/64	0.0469	35/64	0.5469
1/16	0.0625	9/16	0.5625
5/64	0.0781	37/64	0.5781
3/32	0.0938	19/32	0.5938
7/64	0.1094	39/64	0.6094
1/8	0.1250	5/8	0.6250
9/64	0.1406	41/64	0.6406
5/32	0.1562	21/32	0.6562
11/64	0.1719	43/64	0.6719
3/16	0.1875	11/16	0.6875
13/64	0.2031	45/64	0.7031
7/32	0.2188	23/32	0.7188
15/64	0.2344	47/64	0.7344
1/4	0.2500	3/4	0.7500
17/64	0.2656	49/64	0.7656
9/32	0.2812	25/32	0.7812
19/64	0.2969	51/64	0.7969
5/16	0.3125	13/16	0.8125
21/64	0.3281	53/64	0.8281
11/32	0.3438	27/32	0.8438
23/64	0.3599	55/64	0.8594
3/8	0.3750	7/8	0.8750
25/64	0.3906	57/64	0.8906
13/32	0.4062	29/32	0.9062
27/64	0.4219	59/64	0.9291
7/16	0.4375	15/16	0.9375
29/64	0.4531	61/64	0.9531
15/32	0.4688	31/32	0.9688
31/64	0.4844	63/64	0.9844
1/2	0.5000	1	1.0000

To Convert To:	To Convert From:	Multiply By:
Bars	Pounds / Square Feet	2089
Centimeters	Feet	0.03281
Centimeters	Inches	0.3937
Degrees Farenheit	Degrees Centigrade	toC=(toF-32)/1.8
Degrees Centigrade	Degrees Farenheit	toF=1.8*toC+32
Foot	Meter	0.3048
Foot	Millimeter	304.8
Foot / Minute (Fpm)	Meter / Second (M/Min)	0.3048
Foot / Minute (Fpm)	Meter / Second (M/Sec)	0.00508
Inch	Millimeter	25.4
Inch	Meter	0.0254
Inch ²	Meter ²	0.000645
Inch / Second (In/Sec)	Meter / Second (M/Sec)	0.0254
Kilograms (Kg)	Pounds (Lbs.)	2.2046
Kilograms / Sq. Centimeter (Kg/Cm ²)	Pound / Sq. Inch (Psi)	14.223
Kilogram-Force (Kgf)	Newton (N)	9.81
Kilogram-Force-Meter	Newton-Meter (N*M)	9.81
Meter	Feet	3.281
Meter / Minute (M/Min)	Feet / Minute (Fpm)	3.281
Micron	Thousandths	0.03939
Millimeter	Inch	0.03937
Newton (N)	Pound-Force (Lbf)	0.2248
Newton (N)	Kilograms (Kg)	0.1019
Newton-Meter (Nm)	Inch-Pounds	8.851
Newton-Meter (Nm)	Foot-Pound	0.7376
Pounds (Lbs)	Kilograms (Kg)	0.4536
Pound-Force (Lbf)	Newton (N)	4.4482
Pound-Force-Inch (In-Lbs.)	Newton-Meter (N*M)	0.11298
Pound-Force-Foot (Ft-Lbs.)	Newton-Meter (N*M)	1.3558
Pounds / Inch ² (Psi)	Kilograms / Centimeter ² (K/Cm ²)	0.07028
Pounds / Inch ² (Psi)	Bar	0.06894
Square Inches (In ²)	Square Millimeters (Mm ²)	645.16
Square Millimeters (Mm ²)	Square Inches (In ²)	0.00155
Thousandths	Microns	25.4



Grease Charts

Stainless Steel

Grease Name	Dropping Point (°F)	Penetration 60x	Thickener	Temp. Range (°F)	Features
Shell Alvania RL2	385	284	Lithium	-30 to 275	Low Noise – General Purpose & Electric Motors - Replaces Alvania 2/3
Shell Alvania RL3	385	240	Lithium	-30 to 275	
Shell Alvania EP	385	275	Lithium	-10 to 275	Extreme Pressure
Shell Darina 2	500+	280	Microgel	-10 to 350* (*with frequent Lubrication)	High Temperature & Water Resistant
Shell Dolium BRB	500+	285	Polyurea	-30 to 350 (400 short exposure)	High Speed. High Temp. Corrosion Resistant
Exxon Beacon 325	350	285	Lithium	-50 to 250	Low Temperature
Exxon Polyrex EM	550	284	Polyurea	-40 to 350	Electric Motor Grease – High Temp. – Low Noise
Chevron SRI-2	470	280	Polyurea	-20 to 350	High Temp – Excellent Rust Protection
Mobil 28	590	280	Clay (non soap)	-60 to 350	High Temp. High Wear Synthetic Grease – Mil -G81322E
Mobil FM222	400	280	Aluminum Complex	-20 to 175	Food Grade Grease – Water Resistant – Corrosion Protection
Kluber Isoflex LDS18	375	270	Lithium	- 50 to 280	High Speed – Low Noise
Kluber Isoflex NBU15	480	270	Lithium	- 30 to 250	High Speed
Kyodo Yushi Multitemp SRL	365	230	Lithium	-50 to 300	Low Noise
Hangu #2	385	275	Lithium	-10 to 130	Food Grade Grease -Low Noise

The numbers in the above are for information purpose only.
Consult the manufacturers' web sites for more details.

Maximum Set Screw Torque for Stainless Steel Inserts

Bearing no.	Set Screw	Torque Nm	Torque in/lbs
SUC 204-206	M6 x 1 1/4-28 UNF	3.3	29.2
SUC 207-209	M8 x 1 5/16-24 UNF	6.8	60.2
SUC 210-212	M10 x 1.25 3/8-24 UNF	12.6	111.5