

Dual Seal

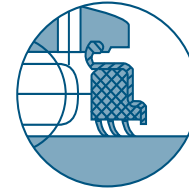

Triple Seal optional

Unit No.	Shaft Dia. Inch / mm d	Dimensions Inch / mm								Basic load rating lbf / N		Weight kg / lbs	
		D	B	C	S	S1	G	h	ds	dynamic	static	kg	lbs
UC 201 201-8 202 202-9 202-10 203 203-11 204 204-12	12 mm 1/2 15 mm 9/16 5/8 17 mm 11/16 20 mm 3/4	1.8504 47	1.2205 31	0.6693 17	0.500 12.7	0.720 18.3	0.1850 4.7	0.1378 3.5	1/4-28UNF M6x1	2878 12800	1495 6650	0.21 0.20 0.19 0.19 0.19 0.18 0.18 0.16 0.17	0.46 0.44 0.42 0.42 0.42 0.40 0.40 0.35 0.37
UC 205 205-14 205-15 205-16	25 mm 7/8 15/16 1	2.0472 52	1.3425 34.1	0.6693 17	0.5630 14.3	0.780 19.8	0.1969 5	0.1653 4.2	1/4-28UNF M6x1	3152 14020	1771 7880	0.22 0.20 0.19 0.19	0.48 0.44 0.42 0.42
UC 206 206-17 206-18 206-19 206-20	30 mm 1-1/16 1-1/8 1-3/16 1-1/4	2.4409 62	1.500 38.1	0.7480 19	0.6260 15.9	0.8740 22.2	0.1969 5	0.1969 5	1/4-28 UNF M6 X 1	4375 19460	2542 11310	0.34 0.31 0.32 0.31	0.75 0.68 0.70 0.68
UC 207 207-20 207-21 207-22 207-23	35 mm 1-1/4 1-5/16 1-3/8 1-7/16	2.8346 72	1.6890 42.9	0.7874 20	0.6890 17.5	1.000 25.4	0.2360 6	0.2244 5.7	1/4-28 UNF M8x1	5771 25670	3439 15300	0.52 0.50 0.48 0.46 0.46	1.14 1.10 1.06 1.01 1.01
UC 208 208-24 208-25	40 mm 1-1/2 1-9/16	3.1496 80	1.9370 49.2	0.8268 21	0.748 19	1.189 30.2	0.315 8	0.2480 6.3	5/16-24 UNF M8 X 1	6550 29100	4000 17800	0.68 0.64 0.63	1.50 1.41 1.39
UC 209 209-26 209-27 209-28	45 mm 1-5/8 1-11/16 1-3/4	3.3465 85	1.9370 49.2	0.8660 22	0.7480 19.0	1.1890 30.2	0.3150 8	0.2480 6.3	5/16-24UNF M8 X 1	7119 31670	4649 20680	0.78 0.74 0.70 0.70	1.72 1.63 1.54 1.54

Normal Duty

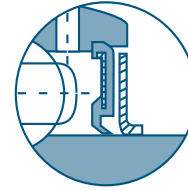
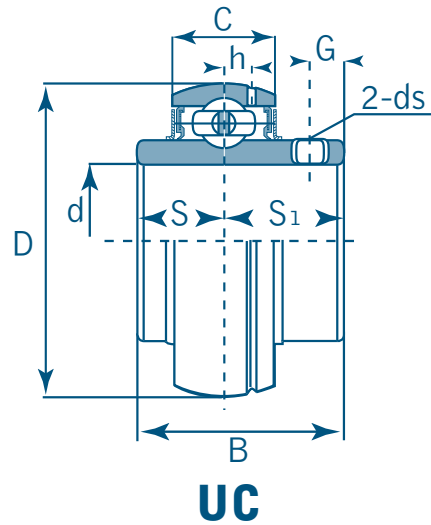

Dual Seal



Triple Seal optional

Unit No.	Shaft Dia. Inch / mm d	Dimensions Inch / mm								Basic load rating lbf / N		Weight	
		D	B	C	S	S1	G	h	ds	dynamic	static	kg	lbs
		UC 210 210-30 210-31 210-32	50 mm 1-7/8 1-15/16 2	3.5433 90	2.0315 51.6	0.9449 24	0.7480 19.0	1.2835 32.6	0.3937 10	0.2598 6.6	3/8-24UNF M10x1.25	7884 35070	5211 23180
UC 211 211-32 211-34 211-35	55 mm 2 2-1/8 2-3/16	3.9370 100	2.1890 55.6	0.9843 25	0.874 22.2	1.3150 33.4	0.3937 10	0.2755 7	3/8-24UNF M10x1.25	9752 43380	6569 29220	1.11 1.26 1.15 1.09	2.44 2.77 2.53 2.40
UC 212 212-36 212-38 212-39	60 mm 2-1/4 2-3/8 2-7/16	4.3307 110	2.5630 65.1	1.0630 27	1.000 25.4	1.5630 39.7	0.394 10	0.2292 7.6	3/8-24UNF M10x1.25	10736 47760	7403 32930	1.54 1.67 1.52 1.45	3.39 3.67 3.34 3.19
UC 213 213-40	65 mm 2-1/2	4.7244 120	2.5630 65.1	1.1024 28	1.000 25.4	1.5630 39.7	0.394 10	0.3503 8.9	3/8-24UNF M10x1.25	12861 57210	8992 40000	1.85 1.94	4.07 4.27
UC 214 214-43 214-44	70 mm 2-11/16 2-3/4	4.9213 125	2.9370 74.6	1.1811 30	1.189 30.2	1.7480 44.5	0.472 12	0.3503 8.9	7/16-20UNF M12x1-1/2	13675 60830	10123 45030	2.05 2.16 2.06	4.51 4.75 4.53
UC 215 215-47 215-48	75 mm 2-15/16 3	5.1181 130	3.0630 77.8	1.2598 32	1.311 33.3	1.7520 44.5	0.472 12	0.3503 8.9	7/16-20UNF M12x1-1/2	14862 66110	11128 49500	2.21 2.24 2.12	4.86 4.93 4.66
UC 216 216-50	80 mm 3-1/8	5.1181 140	3.2520 82.6	1.2992 33	1.311 33.3	1.9410 49.3	0.5512 14	0.3779 9.6	7/16-20UNF M12x1-1/2	16298 72500	11914 53000	2.80 2.85	6.16 6.27
UC 217 217-52 217-55	85 mm 3-1/4 3-7/16	5.9055 150	3.3740 85.7	1.3780 35	1.3425 34.1	2.0315 51.6	0.5512 14	0.3779 10	7/16-20UNF M12x1-1/2	18771 83500	14387 64000	3.46 3.68 3.25	7.61 8.10 7.15
UC 218 218-56	90 mm 3-1/2	6.2992 160	3.7795 96	1.4567 37	1.5630 39.7	2.2165 56.3	0.5903 15	0.4330 11	1/2-20UNF M12x1-1/2	21581 96000	16073 71500	4.36 4.47	9.59 9.83